



INTERNATIONAL SKELETON RULES 2024

In order to allow easy traceability of the changes compared to 2023 we have highlighted them in yellow.

Table of Contents

1.	IBSF COMPETITIONS	6
1.1.	OLYMPIC WINTER GAMES	6
1.1.1.	<i>Olympic Winter Games</i>	6
1.1.2.	<i>Winter Youth Olympic Games</i>	6
1.2.	CHAMPIONSHIPS	6
1.2.1.	<i>World Championships</i>	6
1.2.2.	<i>Junior World Championships</i>	6
1.2.3.	<i>Continental Championships</i>	6
1.2.3.1.	<i>European Championships</i>	6
1.2.4.	<i>Junior Continental Championships</i>	6
1.2.4.1.	<i>Junior European Championships</i>	6
1.2.5.	<i>Para World Championships</i>	6
1.2.6.	<i>Summer Push World Championships</i>	6
1.3.	OFFICIAL IBSF COMPETITIONS	6
1.3.1.	<i>World Cup Competitions</i>	6
1.3.2.	<i>Intercontinental Cup Competitions</i>	6
1.3.3.	<i>Asian Cup, Europe Cup and North American Cup Competitions</i>	6
1.3.4.	<i>IBSF Sanctioned Competitions</i>	6
1.3.5.	<i>Para World Cup Competitions</i>	6
1.3.6.	<i>Youth Competitions</i>	6
1.3.7.	<i>Summer Push Competitions</i>	6
1.4.	TEST COMPETITIONS AND INTERNATIONAL TRAINING PERIOD	6
1.5.	ALLOCATION OF COMPETITIONS	8
1.6.	GENDER	8
2.	DISCIPLINES	8
2.1.	MEN'S SKELETON	8
2.2.	WOMEN'S SKELETON	8
2.3.	TEAM COMPETITION	8
2.3.1.	<i>Skeleton Mixed Team</i>	8
2.3.2.	<i>Bobsleigh/Skeleton Mixed Team</i>	8
2.4.	OTHER DISCIPLINES	8
2.4.1.	<i>Para Skeleton (see IBSF Para Skeleton Rules)</i>	8
2.4.2.	<i>Summer Push (see IBSF Summer Push Rules)</i>	8
2.4.3.	<i>Youth Competitions (see IBSF Youth Rules)</i>	8
3.	ADMISSION	8
4.	RIGHT TO PARTICIPATE IN COMPETITIONS	9
4.1.	OLYMPIC WINTER GAMES	9
4.2.	WORLD CHAMPIONSHIPS	9
4.2.1.	<i>Requirements for participation in the World Championships</i>	9
4.3.	JUNIOR WORLD CHAMPIONSHIPS	10
4.3.1.	<i>Requirements for participation in the Junior World Championships:</i>	10
4.4.	CONTINENTAL CHAMPIONSHIPS	10
4.5.	WORLD CUP	11
4.6.	ASIAN CUP, EUROPE CUP AND NORTH AMERICAN CUP	12
4.6.1.	<i>Asian Cup</i>	12
4.6.2.	<i>Europe Cup</i>	12
4.6.3.	<i>North American Cup</i>	12
4.7.	SKELETON MIXED TEAM	13
4.8.	IBSF SANCTIONED COMPETITIONS	13
5.	EVENT	13
5.1.	GENERAL	13
5.2.	COSTS	13
5.3.	TRACK	13
5.4.	EVENT ANNOUNCEMENTS AND INVITATIONS	13

5.5.	ORGANIZING COMMITTEE AND RACE DIRECTOR	14
5.6.	TECHNICAL EQUIPMENT	14
5.7.	LIABILITY INSURANCE	15
5.8.	FURTHER OBLIGATIONS OF THE ORGANIZER.....	15
6.	JURY AND TECHNICAL DELEGATES	15
6.1.	JURY LICENSE	15
6.2.	LICENSE FOR MATERIAL CONTROLS.....	15
6.3.	NOMINATION.....	16
6.3.1.	<i>Olympic Winter Games</i>	16
6.3.2.	<i>World Championships</i>	16
6.3.3.	<i>Junior World Championships, Continental Championships and World Cup</i>	16
6.3.4.	<i>Asian Cup, Europe Cup and North American Cup</i>	16
6.3.5.	<i>IBSF Sanctioned Competitions</i>	16
6.4.	AUTHORITY	16
6.4.1.	<i>Jury</i>	16
6.4.2.	<i>Technical Delegates</i>	17
6.4.3.	<i>Attendance</i>	17
6.4.4.	<i>Expenses</i>	17
6.4.5.	<i>Authority to Inspect</i>	17
6.4.6.	<i>Special Decisions</i>	17
7.	RACE DIRECTOR	18
7.1.	APPOINTMENT	18
7.2.	DUTIES.....	18
8.	GENERAL REGULATIONS	18
8.1.	SPORTING YEAR	18
8.2.	LIABILITY.....	18
8.3.	AMATEURISM RULES.....	18
8.4.	LICENSES.....	18
8.5.	INSURANCE	19
8.6.	ENTRIES	19
8.7.	ACCEPTANCE OF THE INTERNATIONAL RULES	20
8.8.	TRACK RECORDS AND START RECORDS.....	20
8.9.	DOPING CONTROLS	20
8.10.	RULE VIOLATIONS	20
8.10.1.	<i>Athlete Support Person Rule Violations</i>	21
8.10.2.	<i>Prohibited Association</i>	21
8.10.3.	<i>Burden of Proof</i>	21
8.11.	SPONSORSHIP AND ADVERTISING.....	21
8.12.	TRADEMARKS ON EQUIPMENT.....	21
8.12.1.	<i>IBSF Properties</i>	21
8.12.2.	<i>Freely Available Advertising Areas</i>	22
8.13.	GENERAL PRINCIPLES	22
9.	MEDICAL SERVICE AT THE TRACK	23
9.1.	RACE MEDICAL	23
9.2.	TEAM MEDICAL/DOCTOR	24
9.3.	EVACUATION OF INJURED ATHLETES.....	24
10.	THE COMPETITION	24
10.1.	OFFICIAL TRAINING.....	24
10.1.1.	<i>Olympic Winter Games and World Championships</i>	24
10.1.2.	<i>Continental Championships and World Cup</i>	24
10.1.3.	<i>Junior World Championships, Asian Cup, Europe Cup and North American Cup</i>	24
10.1.4.	<i>IBSF Sanctioned Competitions</i>	24
10.1.5.	<i>Changes to Official Training</i>	24
10.2.	STARTING ORDER DURING TRAINING.....	25
10.2.1.	<i>Olympic Winter Games:</i>	25

10.2.2.	World Championships:	25
10.2.3.	All other official IBSF races according to rule point 1.3:	25
10.3.	TRACK CONDITIONS DURING TRAINING	26
10.4.	START GROOVES	26
10.5.	REPLACEMENT OF ATHLETES.....	26
10.6.	THE RACE.....	26
10.6.1.	Race Heats	26
10.6.2.	Starting Order	27
10.6.3.	Starting Order System	27
10.6.4.	Start Number	28
10.6.5.	Athletes and Manner of driving	29
10.6.6.	Track Conditions during the Race	29
10.6.7.	Track Walks	29
10.6.8.	Start	30
10.6.9.	Reaction Start	30
	The IBSF will publish a starting procedure protocol.	30
10.6.10.	Reduction	30
10.6.11.	Interruption or Cessation	30
10.6.12.	Repetition of a Heat	30
10.6.13.	Replacement Races	30
10.6.14.	Pilot Sleds	31
10.6.15.	Timing Equipment specifications	31
10.6.16.	Time Measurement	32
10.6.17.	Maintenance of the timing equipment (in place from 2017/18 season on)	33
10.6.18.	Use of push start facility	33
10.7.	PARC FERMÉ	33
10.8.	MATERIAL AND EQUIPMENT	34
10.8.1.	Sled	34
10.8.2.	Runners (General)	34
10.9.	TECHNICAL INSPECTIONS	35
10.10.	RUNNER DIAMETER	35
10.11.	MEASUREMENT OF RUNNER TEMPERATURES	35
10.12.	REFERENCE RUNNER.....	36
10.13.	RUNNER CLEANING.....	36
10.14.	WEIGHT.....	37
10.15.	ELECTRONIC MEASURING DEVICES AND EQUIPMENT.....	37
10.16.	OTHER EQUIPMENT	38
10.16.1.	Helmet	38
10.16.2.	Shoes	38
10.16.3.	Clothing	39
10.17.	AWARDS.....	39
10.17.1.	IBSF Championships	39
10.17.2.	Official IBSF Competitions	39
10.18.	AWARDS CEREMONY.....	39
10.19.	PROTESTS	40
11.	RANKING LISTS	40
11.1.	DISCIPLINE RANKING LIST OF THE RACE SERIES	40
11.2.	IBSF DISCIPLINE RANKING LIST	40
11.3.	IBSF RANKING LIST – POINTS	42
12.	SKELETON SLEDS WITH DRAWINGS	45
12.1.	BASIC PRINCIPLES.....	45
12.2.	CONSTRUCTION	45
12.3.	DIMENSIONS (FIGURES 1, 2 & 3)	46
12.4.	FRAME (FIGURES 1, 2, 4 & 7)	46
12.5.	SADDLE AND SADDLE PLATES (FIGURES 1, 2 & 3)	47
12.6.	COWLING AND SUPPORTING SURFACE (FIGURES 1, 3 & 6)	47
12.7.	RUNNERS (FIGURE 5).....	47
12.8.	BUMPERS (FIGURE 1, 2 & 3).....	48

12.9.	DRAWINGS	50
12.10.	EQUIPMENT	53
13.	MATERIAL SEIZURE	54
13.1.	PROCEDURE FOR THE SEIZURE OF SLED COMPONENTS FOR CONFORMITY TESTS	54
13.2.	THE FORM	54
13.3.	THE CONTAINER.....	54
13.4.	REMARKS	54
14.	ADVERTISING GUIDELINES AND DRAWINGS	56
15.	FINAL CLAUSES	57
15.1.	COMING INTO FORCE	57
15.2.	MODIFICATIONS	57
15.3.	INTERPRETATION.....	57
16.	GLOSSARY	58

1. IBSF COMPETITIONS

The IBSF competitions consist of the following events:

1.1. Olympic Winter Games

- 1.1.1. Olympic Winter Games**
- 1.1.2. Winter Youth Olympic Games**

1.2. Championships

- 1.2.1. World Championships**
- 1.2.2. Junior World Championships**
- 1.2.3. Continental Championships**
 - 1.2.3.1. European Championships**
- 1.2.4. Junior Continental Championships**
 - 1.2.4.1. Junior European Championships**
- 1.2.5. Para World Championships**
- 1.2.6. Summer Push World Championships**

1.3. Official IBSF Competitions

- 1.3.1. World Cup Competitions**
- 1.3.2. Intercontinental Cup Competitions**
- 1.3.3. Asian Cup, Europe Cup and North American Cup Competitions**
- 1.3.4. IBSF Sanctioned Competitions**
- 1.3.5. Para World Cup Competitions**
- 1.3.6. Youth Competitions**
- 1.3.7. Summer Push Competitions**

1.4. Test Competitions and International Training Period

The Organizers of IBSF competitions to be staged on newly constructed tracks shall offer all Members enough training in advance, during the preceding season respectively during the same season of the competition.

Training heats prior to races are to be offered also on any tracks that have been subject to constructional changes.

The Organizers of the Winter Olympic Games to be staged on newly constructed tracks shall offer a number of at least 40 training and competition heats prior to the OWG to all Members. These training heats and competition heats must be offered in the form of two or more International Training periods, scheduled throughout the season. Video footage obtained by IBSF during homologation will be made available to all National Federations.

Prior to the OWG, the Organizers must also hold at least one test competition.

The quotas for participation in the International Training periods and in the test event are the same as for the World Cup of the season in which the International Training periods and/ or test event are held.

Furthermore, the following nations can participate in the International Trainings periods and/or test event with 1 male or 1 female athlete:

- a) men the first 7 nations,
- b) women the first 5 nations

not qualified for the World Cup, provided that these athletes have taken part in and been ranked in, a minimum of 5 IBSF competitions on a minimum of 3 different tracks in the course of the previous 24 months.

Nations that do not have the right to compete in the World Cup, may not participate with their athletes in the "Test event" but their athletes can train during this time.

Moreover, for reasons of fairness and safety, immediately prior to the start of official training for the Olympic competitions (whether before or after the Opening Ceremony), the athletes (male and female athletes) registered for the Olympic Winter Games must be given the possibility of at least 4 training heats.

Male and female athletes who are placed in the top 15 of the IBSF Discipline Ranking in the previous and/or current season cannot do additional training heats beyond the number prescribed by the present Article. This does not apply to athletes from the host country.

Moreover, the Organizer of the training periods and Test Event must grant that all participating athletes and their assistants/coaches will be provided with lodging in at least a three star hotel, full board, at a maximum price of € 110,-- per day/double room.

The Organizer of the World Championships must offer an International Training period, to prepare for them and it must take place during the same competitive season in which the World Championships are organized. This International Training Period must comprise at least 4 training days with 3 trainings runs per day and has to be approved by the IBSF. The Organizer is exempt from doing this if during the preceding competitive season a World Cup competition had been organized on the same track.

During the International Training Periods in preparation for the Olympic Winter Games and/or World Championships, the Organizer shall offer training heats upon payment of the following amount: a maximum of € 12 for each Skeleton training heat shall be offered.

If the training period is to be staged as a test competition, the Organizer must offer the heats free of charge.

However, the Organizer may require payment of the entry fee.

1.5. Allocation of Competitions

a) World Championships

The Congress assigns the World Championships to the respective Member Federations a maximum of four years in advance upon written application.

b) Official IBSF Competitions

The remaining official IBSF competitions are assigned yearly by the IBSF Executive Committee, and must be listed on the IBSF International Calendar.

1.6. Gender

If the IBSF International Rules do not explicitly indicate the gender, they apply to both men's and women's Skeleton.

2. DISCIPLINES

The following disciplines are contested:

2.1. Men's Skeleton

2.2. Women's Skeleton

2.3. Team Competition

2.3.1. Skeleton Mixed Team

2.3.2. Bobsleigh/Skeleton Mixed Team

2.4. Other Disciplines

2.4.1. Para Skeleton (see IBSF Para Skeleton Rules)

2.4.2. Summer Push (see IBSF Summer Push Rules)

2.4.3. Youth Competitions (see IBSF Youth Rules)

3. ADMISSION

The right to participate in championships and official IBSF competitions is reserved only for athletes registered by IBSF Members.

The athletes must fulfill one of the following conditions:

a) They must hold citizenship of the country of the Member concerned, and may not have taken part in international IBSF competitions on behalf of another Member, or

b) They must have their official residence in the country of the Member concerned, and may not have taken part in international IBSF competitions on behalf of another Member, or

- c) They must have changed their citizenship or their official residence, and have been released by their former Member and accepted by their new Member. In this case, the athlete may represent one of the two Members, but not both.

An athlete may represent only one nation during any competition season, which lasts from October 1st to September 30th of the following year.

Applications to change Federations may only be submitted between March 31st and September 30th of each year.

When athletes switch nations, they keep their scores and ranking in the IBSF Ranking List, as well as the number of competitions in which they have participated; however, they do not keep the right to the previous quotas for participation, which remains tied to the nation of origin.

4. RIGHT TO PARTICIPATE IN COMPETITIONS

4.1. Olympic Winter Games

The criteria for the right to participate in the Olympic Winter Games are determined by the IOC. The qualification rules are determined by the IOC in collaboration with the IBSF. The qualification rules are communicated directly by the IOC to all National Olympic Committees.

4.2. World Championships

The World Championships take place annually, with the exception of the Olympic year. Quotas are based on the current IBSF World Cup Ranking List.

The quotas for participation in the World Championships are as follows:

- Men and Women: Nations 1 - 3 with 3 athletes
- Nations 4 - 11 with 2 athletes
- Nations 12 - 20 with 1 athlete

The 1st, 2nd and 3rd placed athlete(s) of the Junior World Championships are entitled to participate in the World Championships but the maximum number of three athletes per nation and discipline may not be exceeded for the World Championships.

4.2.1. Requirements for participation in the World Championships

Participation is allowed only for athletes within the current IBSF World Cup Ranking List, except athletes qualified through Junior World Championships as described in rule point 4.2. World Championships.

Nations must fulfill the following quota requirements in order to be eligible for the entire World Championship quota allocation:

- Nations must have competed in 50 % of their total confirmed World Cup quota allocation within the discipline during the current season prior to the World Championships. In case the calculated, required number of races holds decimals, the value should be rounded down to the whole number. Nations must confirm their World Cup quota allocation by October 1st of the respective season. If no written confirmation has been received by the IBSF, the full quota will be applied. Quota reallocation is not possible.

If a Nation fails to meet the quota requirements above, they would lose one quota spot within the respective discipline for the upcoming World Championships.

4.3. Junior World Championships

The Junior World Championships take place annually. Only athletes from the Junior category may participate. Junior World Championships shall stage the following disciplines: Women's Skeleton, Men's Skeleton and the Skeleton Mixed Team.

There will be an additional category for athletes that have not reached 20 years (U20 category). The U20 athletes will compete in the same race, but additionally will have their own results list and a Junior World Champion U20 will be named from this list.

The Junior World Champion is taken from the overall results list regardless of age and competition.

4.3.1. Requirements for participation in the Junior World Championships:

Participation is allowed only for athletes who have taken part in, and been ranked in, a minimum of 3 IBSF competitions on a minimum of 2 different tracks in the course of the previous 24 months.

Juniors are athletes who reached the age of maximum 23 years (or 20 years for U20) in the period of October 1st to March 31st of the current season.

The Junior World Championships take place annually. Only athletes from the Junior category may participate. All National Federations may participate with a maximum of 3 athletes. If one registered athlete is eligible for the U20 category, the nation may register one additional athlete, so in total a maximum of 4 athletes.

4.4. Continental Championships

The quotas for participation in the Continental Championships are identical to those of the World Cup if the Championships are held within the course of a World Cup competition. Nations of the respective continent that are not qualified to participate in the World Cup have the right to participate with one athlete. These athletes are ranked only in the Continental Championships and shall receive no World Cup points. They are drawn separately at the end of the field of competitors.

These athletes start at the end of the field of competitors corresponding to their place in the IBSF rankings. The starting order for athletes without points is drawn by raffle.

In the second race heat, they start according to their ranking after the first heat.

In the event that Continental Championships are not held as part of a World Cup race, the number of participants per discipline is limited to 3, with the names of the athletes to be announced to the Jury President on the occasion of the draw for the race. For these races no points will be awarded for the IBSF ranking.

The Junior Continental Championships will be held in the framework of the corresponding Asian Cup, Europe Cup respectively North American Cup of the current season. In relation to the Junior European Championships Juniors are athletes who reached the age of maximum 23 years (or 20 years for the U20 category) in the period of October 1st to March 31st of the current season.

There will be an additional category for athletes that have not reached 20 years (U20 category). The U20 athletes will compete in the same race, but additionally will have their own results list and a Junior Continental Champion U20 will be named from this list.

The Junior Continental Champion is taken from the overall results list regardless of age and competition.

4.5. World Cup

Quotas for the new season are based on the final results of the previous year's IBSF Ranking List.

Nations must confirm their World Cup quota allocation by October, 1st of the respective season. If no written confirmation has been received by the IBSF, the full quota will be applied. Quota reallocation is not possible.

If a female athlete misses out for one season due to maternity leave, this female athlete will keep her quota spot in the respective race series when coming back after one season. This quota place will be linked to the single female athlete's name, cannot be transferred to another athlete and will be in addition to the quota spot/s assigned to the National Federation.

The quotas for participation are determined as follows:

Men and Women:

Nations 1 - 2 4 athletes in the Top 70 (Men) / Top 55 (Women)

Nations 3 - 6 3 athletes in the Top 70 (Men) / Top 55 (Women)

Nations 7 – 12 2 athletes in the Top 70 (Men) / Top 55 (Women)

Requirements for all remaining Nations are determined as follows:

Men: Nations with one athlete in the Top 70: 1 starting place

Women: Nations with one athlete in the Top 55: 1 starting place

The criteria for participation are based on the previous year's IBSF Ranking List.

If a Nation fulfills the Requirements for a World Cup spot within the ongoing Olympic cycle*, this Nation will also be granted with a Quota Spot on World Cup and will keep it for the whole Olympic cycle.

Requirement for participation in the Continental Championships and World Cups:

Participation is allowed only for athletes who have taken part in, and been ranked in, a minimum of 8 IBSF competitions on a minimum of 3 different tracks in the course of the previous 48 months.

If a pilot has fulfilled this qualification criteria by October 1st of the respective season, it remains valid for the entire current season.

4.6. Asian Cup, Europe Cup and North American Cup

4.6.1. Asian Cup

The quotas for participation are determined as follows:

Men: Nations from Asia, America, Africa and Oceania with a maximum of 6 athlete.

Europe with a maximum of 4 athletes.

Women: Nations from Asia, America, Africa and Oceania with a maximum of 6 athletes.

Europe with a maximum of 4 athletes.

4.6.2. Europe Cup

The quotas for participation are determined as follows:

Men: Nations from Europe with a maximum of 6 athletes.

All remaining nations from Africa, America, Asia and Oceania with a maximum of 4 athletes.

Women: Nations from Europe with a maximum of 6 athletes.

All remaining nations from Africa, America, Asia and Oceania with a maximum of 4 athletes.

4.6.3. North American Cup

The quotas for participation are determined as follows:

Men: Nations from America, Africa, Asia and Oceania with a maximum of 6 athletes.

Europe with a maximum of 4 athletes.

Women: Nations from America, Africa, Asia and Oceania with a maximum of 6 athletes.

Europe with a maximum of 4 athletes.

* This Rule comes into effect on October 1st, 2023. Therefore, it will be applied only for the period of the 2023/24 season onwards and not retroactively for the 2022/23 season.

4.7. Skeleton Mixed Team

- A Skeleton Mixed Team consists of one male and one female athlete representing the same National Federation. Only those athletes who have registered and qualified for the Women's Skeleton and for the Men's Skeleton of the respective race are eligible to participate.
- With the exception of Olympic Winter Games a maximum of two Teams per National Federation are eligible to participate. The criteria for the right to participate in the Olympic Winter Games are determined by the IOC. The qualification rules are determined by the IOC in collaboration with the IBSF.

4.8. IBSF Sanctioned Competitions

The Organizer together with the IBSF will establish the right to participate, but at a minimum there must be 2 nations per discipline. All IBSF rules and regulations apply unless specifically stated elsewhere in these rules. An athlete may count one (1) of these races as participation in other IBSF competitions per season and discipline.

5. EVENT

5.1. General

Only the IBSF, as well as its Members, have the right to organize international competitions. All official international IBSF competitions shall be organized under the supervision of the IBSF. The IBSF shall award the competition to a Member that is able to undertake the organization of the competition, or is able to pass it on to an association (Club) or an Organizing Committee. The Member remains responsible for the orderly execution of the event.

5.2. Costs

The Organizer to whom the Organization of the event has been awarded assumes the entire organization and its costs.

5.3. Track

The Organizer shall make the track available in the best possible condition for the official training and the race. The usage of the track during the official training and the race is free of charge.

5.4. Event Announcements and Invitations

The Organizer of the competition shall be responsible for the event announcements and invitations.

The Organizer must present the official event announcement with the program schedule to the IBSF Executive Committee for approval by August 15th.

The Organizer must send the program schedule to the Member Federations and the appointed Jury Members within two weeks of receiving the approval of the IBSF.

The event announcement must include:

- a) the name of the competition
- b) the location and date of the competition
- c) a schedule for the official training and the race
- d) a short description of the track, including a sketch of the track
- e) the entry deadline
- f) the address of the Organizing Committee with exact office times, telephone number, fax number and e-mail address
- g) the name of the Chief of Organization
- h) the name of the Race Director
- i) the names of the Jury Members and the Technical Delegate, if any
- j) information about facilities, benefits and hotel accommodations
- k) any conditions of entry
- l) the location and time of the first team captains' meeting

5.5. Organizing Committee and Race Director

An Organizing Committee and a Race Management Office shall be formed in order to guarantee the orderly execution of the event.

The Race Director must possess an IBSF International Jury License. He is responsible for ensuring that the entire event is carried out in accordance with the IBSF International Rules. He shall ensure that skilled and responsible people hold all the important positions in order to assure the smooth progression of the event. Furthermore, he is obliged to ensure that the track is in perfect condition and that the safety of the athletes, coaches and spectators is guaranteed.

5.6. Technical Equipment

- a) voice communication among the start, the finish and the timekeepers
- b) voice communication between the Race Director and the Jury
- c) numerous loudspeakers
- d) at least two calibrated instruments for measuring runner temperature
- e) an electronic timing system
- f) technical infrastructure for implementation of the Skeleton Mixed Team
- g) a room for team captains' meetings
- h) sufficient changing rooms and sanitary facilities
- i) a weight scale, calibrated every year
- j) sufficient transport vehicles
- k) a first aid room
- l) medical service
- m) a doping control room
- n) video surveillance on the track
- o) a room suitable for technical inspections of sleds and runners
- p) a suitable room, possibly next to the start, equipped with Internet connection for the Jury

- q) sufficient computers and photocopiers
- r) a score board
- s) optical and acoustic devices to authorize the start
- t) barricade fences and tape for the Parc Fermé
- u) sufficient and suitable racks for positioning the sleds
- v) A large television screen should be present at the start area during all World Cup events.

5.7. Liability Insurance

The Organizer is obliged to obtain sufficient public liability insurance.

The insurance must cover the IBSF staff involved in the respective competition. Upon request of the other party in a case of a claim, the Organizer must provide all communication and insurance documents in English.

5.8. Further Obligations of the Organizer

The obligations of the Organizer of IBSF competitions are specified in writing within the framework of a contract that is negotiated between the IBSF and the Organizer's National Federation.

The Organizer shall make available all official times recorded during the trainings and the race to the team captains of all participating nations as quickly as possible, preferable by email or in an electronical way. The results should be accessible online. Upon request the official times can be printed. Training and Race results must be uploaded (including a .pdf file) to the IBSF e-license system immediately after the session is finished not later than midnight the same time zone of the Race location and forwarded to the media.

6. JURY AND TECHNICAL DELEGATES

6.1. Jury License

The Jury Members and Technical Delegates, appointed by the IBSF Executive Committee, must possess an IBSF International Jury License in order to officiate. Each National Federation has the right to recommend people suitable for obtaining an IBSF International Jury License.

This License can be acquired after taking an examination on the IBSF International Rules for Bobsleigh and Skeleton. In principle, the examinations take place two times per year, on the occasion of the World Championships and of a World Cup competition on a different continent. The respective National Federations must register potential candidates with the IBSF Secretary General in advance (at least one month prior).

6.2. License for Material Controls

In order to be allowed to execute their office, the Material Controllers appointed by the Executive Committee must have an International Material Controller License of the IBSF. Each National Federation has the right to propose candidates who are eligible to obtain the International Material Controller License of the IBSF. The examinations will be held as

specified by IBSF announcement. The respective National Federations must register potential candidates with the IBSF Secretary General in (at least one month prior).

6.3. Nomination

The IBSF Executive Committee nominates the Juries and the Material Controllers. The National Federations have the right to make recommendations.

6.3.1. Olympic Winter Games

- a) one or two Technical Delegates
- b) a Jury President
- c) two Jury Members
- d) two Jury Assistants, if required
- e) two or three Material Controllers

6.3.2. World Championships

- a) one or two Technical Delegates
- b) a Jury President
- c) two Jury Members
- d) two Jury Assistants, if required
- e) two Material Controllers

6.3.3. Junior World Championships, Continental Championships and World Cup

- a) one or two Technical Delegates
- b) a Jury President
- c) two Jury Members
- d) Jury Assistants, if required
- e) two Material Controllers

6.3.4. Asian Cup, Europe Cup and North American Cup

- a) one or two Technical Delegates
- b) a Jury President
- c) one or two Jury members
- d) one or two Material Controllers

6.3.5. IBSF Sanctioned Competitions

A Jury President or a Technical Delegate who represents the IBSF, with the task of controlling and supervising the event.

6.4. Authority

6.4.1. Jury

The Jury is the highest authority of the competition and implements control with the right to make final judgments within the scope of the IBSF International Rules.

The decision of the Jury is final, incontestable and takes effect immediately.

Furthermore, the Jury is responsible for:

- a) potential changes of the ice temperature
- b) any change of sleds
- c) any change of runners
- d) any repetition of a heat
- e) any reduction in the number of training heats
- f) any interruption or cessation of the race, after consultation with the Race Director and the Chief of Track
- g) any reduction in the number of participants
- h) any penalties for rule violations
- i) the length of the start grooves
- j) the number of pilot sleds
- k) the temperature and weight checks
- l) decisions regarding protests
- m) any suspension of athletes
- n) closing the track in case of danger

6.4.2. Technical Delegates

During the Olympic Winter Games one Technical Delegate for Bobsleigh, one Technical Delegate for Skeleton and one additional Technical Delegate are to be appointed. During the World Championships one Technical Delegate for Bobsleigh and one Technical Delegate for Skeleton are to be appointed.

In principle, for all other IBSF events only one Technical Delegate may be appointed for both disciplines. The power to make decisions regarding the event lies exclusively with the Jury. If no Technical Delegate has been appointed, the Jury President acts automatically also as Technical Delegate.

6.4.3. Attendance

The Jury President must be available from the first team captains' meeting onward. The Jury is responsible for the compliance with the IBSF International Rules from the start of the official training to the end of the awards ceremony. In cases of absence of a Jury Member, the IBSF appoints a substitute.

6.4.4. Expenses

The IBSF Executive Management Committee determines annually the reimbursement of allowable expenses of the Jury and the Technical Delegate, and informs all concerned by circular letter.

6.4.5. Authority to Inspect

During the training and the race, the Technical Delegate and each Jury Member shall have access without prior notification to all technical equipment and facilities necessary to hold the competition.

6.4.6. Special Decisions

The Jury is also responsible for all decisions pertaining to the competition that are not specified in these Rules.

7. RACE DIRECTOR

7.1. Appointment

The Race Director, appointed by the Organizer, must possess an IBSF International Jury License for all official IBSF competitions.

7.2. Duties

The Race Director is responsible for ensuring that, under the direction of the Jury, all measures are taken that are necessary for the orderly progression of the competition according to the IBSF International Rules. This includes the progression of the team captains' meetings, the training and the race.

Potential necessary changes taken on short notice must first be arranged with the Jury and the IBSF Coordinator.

He shall inform the Jury President immediately about all measures.

In particular, the race director decides upon the use of the sunshades during rain, snowfall or sunshine in consultation with the Technical Delegate, the Coordinator, the Jury and the Track Manager. The use of the sunshades and the sweeping protocol can also be changed during a race or training heat depending on the weather conditions. The final decision will be made by the Jury (for any training, e.g. ITP before and during the Olympic Winter Games and the Youth Olympic Winter Games by the Technical Delegate) in consultation with the Track Manager.

8. GENERAL REGULATIONS

8.1. Sporting Year

The sporting year of the IBSF runs from October 1st to September 30th of the following year.

8.2. Liability

The IBSF assumes no liability for accidents, damages, or other claims that should result from the allocation of the competition or from its proceedings.

8.3. Amateurism Rules

The rules of the IOC are adopted here.

8.4. Licenses

All athletes must be registered electronically by their National Federation for an IBSF International License prior to participating in an IBSF supervised event.

The minimum age for athletes for obtaining an IBSF International License is 13 years of age. Athletes under the age of 18 require the permission of their parents or legal guardian in order

to exercise the sport of Skeleton. The parents or legal guardian must sign the letter of permission and the signature must be certified.

The IBSF Electronic License must be filled out in all details and certified by the President or a duly authorized Officer of the National Federation and submitted with a digital photograph.

By registering for a license, the National Federation verifies and confirms that the athlete:

- a) has had a medical check and has met the medical requirements for Skeleton. The medical check has to be repeated each year, whereas the date of the check shall not be before April 1st to be valid for the upcoming season;
- b) is covered by insurance against accidents deriving from the practice of Skeleton training or racing;
- c) is covered by insurance against liability;
- d) has been issued the IBSF International and Anti-Doping Rules;
- e) has signed a copy of the IBSF Athlete Code of Conduct.
- f) has received at least a basic introduction to Anti-Doping (within the last 3 years) either through an introductory or a refreshment course (in-person or online) offered through the National Anti-Doping Organization (NADO), the National Federation (NF) or by the World Anti-Doping Organization (WADA).

The license is valid for one season (October 1st to September 30th).

8.5. Insurance

The Member Federations of the IBSF are responsible for ensuring that each of their athletes is sufficiently covered by accident and disability insurance, as well as public and third party liability insurance. All risks that may arise from an accident must be completely covered by the insurance.

8.6. Entries

The entry deadline for IBSF events is 4 weeks prior to the 1st Team Captains Meeting and the number of athletes must be specified.

- a) The name of the team captain, with email address, telephone number and accommodation details, must be provided at the time of the entry.
- b) The entries of the athletes for the races must be made online by the Members to the Organizer prior to the deadline specified in the announcement of the event and IBSF detailed race schedule.
- c) The entry fees belong to the Organizer and amount to the value of € 25 per athlete and per race.
- d) Entries may be withdrawn at any time. Already paid entry fees are non-refundable.
- e) Entry fees must be paid as stated in the announcement of the event.
- f) If the entry of an athlete is not withdrawn by the first team captains' meeting, the entry fee must be paid in any case.

8.7. Acceptance of the International Rules

With the submission of the entry, the participants (athletes, team captains, coaches and support staff) accept these Rules as binding.

8.8. Track Records and Start Records

Track records and start records will only be recognized by the IBSF if they have been performed during official international IBSF races. The record may be recognized if the athlete has been subjected to a weight test and their sled to a technical inspection during the competition. If the record is equaled in a subsequent race heat, it does not count as a record. In the event of a draw in the same race heat, more than one athlete may be listed as the record holders. The record cannot be recognized until it has been stated that there have been no violations of the IBSF International Rules.

8.9. Doping Controls

Doping is prohibited.

The IBSF Executive Committee can arrange for doping controls at all IBSF competitions and at any time outside of the competitions.

The doping controls are carried out according to the IBSF Anti-Doping Regulations.

The IBSF Executive Committee can authorize international specialized facilities to carry out these controls.

By signing the IBSF International License, the athlete is obliged to accept the IBSF Anti-Doping Regulations and to submit to the controls determined by the IBSF Executive Committee.

By signing the Acknowledgement and Agreement, the athletes, team captains, technicians, coaches and support staff recognize the new IBSF Anti-Doping Regulations.

8.10. Rule Violations

The Jury is responsible for the compliance with the IBSF International Rules and Code of Conduct or the Olympic Charter during an IBSF competition.

The Jury determines the sanctions for violations against the provisions of the IBSF International Rules and Code of Conduct, e.g. unsportmanlike behaviour according to the gravity of the offence:

- a) a warning
- b) a fine
- c) disqualification from the competition
- d) application for disqualification from other competitions to the Executive Committee
- e) application to the Executive Committee for withdrawal of the international License

The athlete concerned or his National Federation has the right to defend himself before a final decision is made regarding the cancellation of the IBSF International License. The fine is collected by the Jury, which forwards it to the IBSF.

8.10.1. Athlete Support Person Rule Violations

An Athlete Support Person (Coach, sled or runner builder, physio or any other person) may be deemed to have broken or contributed to the breaking of IBSF International Rules, any Code of Conduct or the Olympic Charter during an IBSF competition, e.g. unsportmanlike behaviour. In this case the Jury can determine immediately the sanction for the violation according to the gravity of the offence:

- a) a warning
- b) a fine
- c) exclusion from the competition / venue
- d) application for exclusion from future IBSF competitions to the Executive Committee

8.10.2. Prohibited Association

In the event that an Athlete Support Person is disqualified from an IBSF event or events (8.10.1) it is prohibited for an athlete (athletes, team or nation) to associate with this person for the duration of their disqualification. If after receiving a written warning the athlete (athletes, team or nation) continues to associate with the disqualified person the athlete (athletes, team or nation) may be given a

- a) fine
- b) disqualification from the competition
- c) disqualification from future competitions

In order for this provision to apply, it is necessary that the athlete (athletes, team or nation) has been advised in writing by the IBSF of the Athlete Support Person's disqualifying status and the potential consequence of prohibited association and that the athlete can reasonably avoid the association.

8.10.3. Burden of Proof

The burden shall be on the athlete (athletes, team or nation) to establish that any association with the Athlete Support Personnel described in Article 8.10.1 or 8.10.2 is not in a professional or sport-related capacity.

8.11. Sponsorship and Advertising

The IBSF and its Member Federations can negotiate contracts with commercial firms or organizations.

8.12. Trademarks on Equipment

8.12.1. IBSF Properties

The IBSF property areas for advertising with sponsors or similar entities are governed by the IBSF Advertising Guidelines. The specifications established therein shall be followed. Violations result in penalties.

8.12.2. Freely Available Advertising Areas

With the exception of the areas entitled to the IBSF in accordance with the IBSF Advertising Guidelines, unlimited advertising may be placed on the sled, the equipment and the athlete.

8.13. General Principles

The IBSF recognizes manufacturer's identification on the equipment for bobsleigh and Skeleton only for those companies who comply with the definition as set out below.

„Competition Equipment“ implies all items of equipment used by athletes in bobsleigh and Skeleton, including clothing, helmets, sleds, runners and other implements that serve a technical function and are manufactured specifically for bobsleigh or Skeleton sports. The entire competition equipment forms a functional unit. In this connection the principle of safety and fairness must be observed.

“Effective Manufacturer” means natural or legal person which (1) itself designs and/or manufactures¹ the Competition Equipment and/or (2) effectively controls and manages the design and/or manufacturing of the Competition Equipment under its own responsibility through customary subcontracting processes, and whose Competition Equipment is effectively offered on the market to end users.

If requested by IBSF, the Effective Manufacturer shall provide documentary evidence of such commercial activities at retail level (such as manufacturing activity in the market of the relevant Competition Equipment, including control over the manufacturing process, retail activity and marketing expenditures linking the brand to the relevant piece of Competition Equipment) as a condition for the commercial markings to be accepted as a Manufacturer's Identification as further defined.

Only manufacturers that have been active over two seasons before the Winter Olympic Games manufacturing Competition Equipment being used in bobsleigh and or Skeleton sports qualify as Effective Manufacturers.

“Manufacturer's Identification” means the name, trademark, brand, logo, or other distinctive sign of the Effective Manufacturer under which the particular Competition Equipment is manufactured and commercially offered to the market (excluding encrypted or encoded supports, such as barcodes or QR codes, as well as URLs, social media accounts and hashtags). The Manufacturer's Identification must be a sports equipment brand, which means that the Manufacturer's Identification is principally used for Competition Equipment and is (i) not principally used for non-sports equipment, and/or (ii) cannot be confused with a similar or identical article used in another line of business, unrelated to Competition Equipment. Should the manufacturer be an individual, the name and surname of such manufacturer is considered Manufacturer's Identification unless provided otherwise.

¹ Design and/or manufacture, as referred to in the above definition, may include specification development, production, fabrication, assembly, processing, of a Competition Equipment; or putting a collection of devices, and possibly other products, together for bobsleigh or Skeleton sports.

9. MEDICAL SERVICE AT THE TRACK

9.1. Race Medical

The following must be available at the track during the official training heats and the race heats:

- a) One medical specialist with certified knowledge/training of emergency medical aid
- b) One medical vehicle used as emergency ambulance
- c) One room exclusively used for first aid treatment – which is marked as such.

Recommended for race days in addition:

One medical doctor with knowledge of sports and able to decide “Fit to slide” – e.g. concussion...

One medical vehicle must be present at all times on the track. In case the medical vehicle is leaving the track training/race must be stopped.

Should medical personal be medically required, training/race must be stopped.

The Organizer shall be attentive to this regulation, as the Organizer is responsible for compliance with these requirements.

The IBSF Medical Committee decides on any possible exceptions to the above. The Jury President must be informed of these exceptions prior to the start of the official training.

Tasks of the race medical:

- a) responsible for the first medical aid for injuries and illnesses of the athlete
- b) coordination of transportation of injured or ill athletes for further medical treatment
- c) after every crash, the athlete must come to the race medical for an examination in order to obtain the authorization to participate further in the training or in the race. If the race medical suspects a concussion or serious injury athletes license must be invalidated ("mark the box on the form"), he is entitled to prohibit the concerned athlete from further participation. In these cases, the race medical must immediately inform the Jury President of the athlete's inability to continue to participate in the competition, and the athlete is accordingly officially removed from the competition. The Jury President immediately will inform the respective IBSF coordinator to temporarily unlicense the concerned athlete. The race medical must complete an Injury Registration Document after every examination of an injured athlete. All of these documents must be forwarded to injury@ibsf.org on a daily basis.

Only a medical doctor can provide "Fit to slide" approval to return to sliding.

9.2. Team Medical/Doctor

Race medical/doctor and team medicals/doctors should cooperate on evaluation and treatment.

9.3. Evacuation of injured athletes

The event Organizers must guarantee that injured athletes can be transported away from any point of the entire length of the track.

10. THE COMPETITION

The competition starts with the 1st Team Captain Meeting and ends after the award ceremony subject to any material control or doping control results and/or any unclosed possible protests of the race concerned. During a competition (the official training and the race), athletes are not permitted to make heats on the track outside of the official schedule, nor are they permitted to conduct training or races on other tracks at the same time or compete on more than one circuit. However, athletes are allowed to conduct training or races on other tracks in the first week of a two-week competition.

In principle, the period right after the race and the day after the race the athlete participated in, is considered as travel day. On IBSF Travel days no athlete may participate in a training or race on another track if an IBSF event is listed in the calendar for that week.

10.1. Official Training

Participation in the official training is only permitted for athletes registered for the race.

10.1.1. Olympic Winter Games and World Championships

Directly prior to the race, 6 official training heats shall be offered.

10.1.2. Continental Championships and World Cup

Directly prior to the race, 2 days of official training with a minimum total of 6 official training heats shall be offered.

10.1.3. Junior World Championships, Asian Cup, Europe Cup and North American Cup

Directly prior to the race, 3 days of official training with a minimum total of 6 official training heats shall be offered.

10.1.4. IBSF Sanctioned Competitions

The Organizer together with the IBSF will determine the number of official training heats. A minimum of 3 official training heats must be offered.

10.1.5. Changes to Official Training

The IBSF can modify the number of official training days and / or training heats in official IBSF competitions. However, the change in the number of official training days and / or

training heats must be declared in the event announcement. At all official IBSF competitions, each athlete must complete two training heats without accident to be allowed to participate in the race.

In general, if the training is conducted from various start heights, the required minimum break between the use of one start height and the use of another is 5 minutes.

10.2. Starting Order during Training

The starting order of the participating nations will be drawn by the technical delegate/coordinator after the registration deadline. If possible, the training is run according to “nation groups”.

10.2.1. Olympic Winter Games:

The starting order of the participating nations will be drawn at the first team captains meeting.

10.2.2. World Championships:

The starting order of the participating nations shall be drawn by the Technical Delegate at the end of the entry term and after the quota allocation and shall be communicated to both the Race Organizer and the participating nations prior to the first team captains’ meeting. Nevertheless, the team captains have to be present at the first team captain meeting in person. If a nation is not present the athletes of the nation concerned shall automatically start at the end of the field during the first and second day.

10.2.3. All other official IBSF races according to rule point 1.3:

The starting order of the participating nations shall be drawn by the responsible coordinator at the end of the entry term and shall be communicated to both the Race Organizer and the participating nations prior to the first team captains’ meeting. Nevertheless, the team captains have to be present at the first team captain meeting in person. If a nation is not present **the jury may impose a fine on the team captain.**

A training cooperation shall not exceed 14 athletes and must be approved by the IBSF Coordinator.

There is no provision for training groups at Olympic Winter Games, as trainings are conducted separately by gender.

The following starting order applies for events in which the official training takes place for 2 or 3 days:

- a) 1st day: from nation 1 to the end
- b) 2nd day: from the end to nation 1
- c) 3rd day: start order according to **the IBSF Discipline Ranking List**
(men and women train separately)

10.3. Track Conditions during Training

If possible, the final day of official training should take place at the same time as the race and the track preparation should correspond to the conditions of the race. No alterations to the track profile should be made after the final training session.

All under-ice-advertising must be in place before the final runs of official training.

10.4. Start Grooves

The start grooves are determined by the Jury on the first day of training and can only be modified upon their command. Both grooves shall be prepared appropriately for Skeleton runners (minimum of 17 mm wide and a depth of 16mm +/- 2mm).

10.5. Replacement of Athletes

It is possible to replace an athlete with another athlete from the same National Federation at any time during training. However, an athlete may only be replaced if the replacement athlete is still able to achieve the minimum number of accident-free training heats without a change in the program schedule.

An athlete who carries out heats beyond the official training (for example, as a pilot sled or in the "guests" class) cannot take part in the competition later on. The Jury can make an exception to allow such athlete's participation in the Team Competition; however, this exception must be declared during the first team captains' meeting.

Double Races:

National Federations may register a maximum of two new athletes for the second race at a WC, NAC and EC competition.

These athletes must be registered no later than the first team captains' meeting and will be allocated with the same number of training heats as the other athletes.

The replacement athlete must hold a valid IBSF International License.

10.6. The Race

10.6.1. Race Heats

An IBSF race can be held over 4 or 2 Heats. A reduction in the number of heats is possible in cases of force majeure. At least one race heat must be conducted for the race to be officially valid.

a) 4-Heat Races

In principle, the Olympic Winter Games and the World Championships are held over 4 heats.

b) 2-Heat Races

The Continental Championships and all other official IBSF races are held over 2 heats.

A Skeleton Mixed Team consists of one male and one female athlete representing the same National Federation. Each athlete does 1 race heat.

- c) Junior World Championships may be held as either 4 or 2 heat races. This will be decided and communicated by the IBSF.

10.6.2. Starting Order

Starting order for 2-Heat races:

- a) 1st race heat: from 1 to the end
- b) 2nd race heat: from 25 to 1, according to the ranking of the 1st race heat

Starting order for Skeleton Mixed Team:

The start order within the team will be female athlete first, followed by male athlete from the same team from team 1 to the end.

Starting order for 4-Heat races:

- a) 1st race heat: from 1 to the end
- b) 2nd race heat: from 25 to 1 and from 26 to the end, according to the ranking of the first race heat or if less than 26 participants, end to 1.
- c) 3rd race heat: from 1 to the end, according to the ranking after two race heats
- d) 4th race heat: from 25 to 1, according to the ranking after three race heats

10.6.3. Starting Order System

For a race to be awarded with IBSF points, a minimum of 6 athletes from a minimum of 2 nations must be drawn for the race. However, in case only 5 or fewer athletes are drawn for the race, no IBSF points will be awarded. Nevertheless, the race will count towards fulfilling the requirements according to rule points 4.2.1, 4.4.1 as well as 4.5.3.

Olympic Winter Games, World Championships and Junior World Championships

In order of their IBSF Discipline Ranking position, the 10 best-placed athletes in the current IBSF Discipline Ranking List who are present will choose their start numbers 1 to 10 for Men's Skeleton and Women's Skeleton. All other athletes start according to the ranking in the current IBSF Discipline Ranking List from start number 11 (Men's and Women's Skeleton) to the end.

Where allowed according to the International Rules Skeleton athletes may choose their start numbers whereas the best placed athlete who is present will choose first, the second best present athlete will choose second and so on.

Winter Youth Olympic Games

In order of their Discipline Ranking position of the race series, the 10 best-placed athletes in the current Discipline Ranking List of the race series who are present will choose their start numbers 1 to 10 for Men's Skeleton and Women's Skeleton. All other athletes start according to the ranking in the current Discipline Ranking List of the race series from start number 11 (Men's and Women's Skeleton) to the end.

Where allowed according to the International Skeleton Rules athletes may choose their start numbers whereas the best placed athlete who is present will choose first, the second best athlete will choose second and so on.

Continental Championships, World Cup, Asian-Cup, Europe Cup and North American Cup

Starting Order Determination:

- a) The season begins based on the previous season IBSF Discipline Ranking List.
- b) For subsequent races within each series, the start numbers 1-10 for Men's Skeleton and Women's Skeleton are assigned through a draw. The 10 best-placed athletes, present in the current IBSF Discipline Ranking List, are drawn.
- c) Start Numbers 11- 20 for Men's and Women's Skeleton are assigned through a draw based on the athletes ranked from 11-20, present on the current IBSF Discipline Rankings List.
- d) Start numbers 21- end for Men's and Women's Skeleton are assigned through a draw based on the remaining ranked athletes present.
- e) Non-ranked athletes are drawn at the end of the field.

Special Cases:

- f) If 10 or fewer athletes are registered for a race, all athletes will be drawn.

The Jury holds the draw in public. An electronic draw by computer is possible. The athletes keep their physical start numbers for the duration of the competition.

At public draws the athletes must be present at the behest of the Jury. If the athlete is not present, he/she will be subject to a sanction to be determined by the Jury.

Skeleton Mixed Team - Olympic Winter Games, World Championships, Junior World Championships, World Cup, Asian Cup, Europe Cup & North American Cup - Starting Order:

The start number will be based on the combined points of the female and male Skeleton Team athlete's points from the current IBSF Discipline Ranking List. The team with the lowest combined points will start first, the team with the highest combined points will start last. In case of equal points, the better overall IBSF Discipline Ranking position of the female athlete will be decisive.

The start order within the team will be female athlete first, followed by male athlete from the same team.

10.6.4. Start Number

The IBSF claims the rights for the start numbers (sled and shirt) for its sponsors.

The start number shirts shall be worn during the race heats. They may be sewn along the sides, but otherwise they may not be aerodynamically modified, nor may they be attached by additional means.

The violation of this rule automatically results in the disqualification from the competition concerned.

World Cup - The IBSF supplies the athletes with the sled start numbers.

All other official IBSF races – The race organizer provides the athletes with the sled start numbers.

The start number for the sled (not exceeding 18 cm x 12 cm) shall be attached to the rear third of the underside of the sled.

The start number may not be modified in any way.

10.6.5. Athletes and Manner of driving

All race heats must be run by the same athlete.

The race doctor or race medical and the Jury are authorized to prohibit athletes in inadequate mental or physical condition to compete.

Only driving from the headfirst prone position (lying on the stomach) is allowed. After the start (when timing commences at the 50 m point) during the race heat, the athlete is not allowed to lose contact with the sled.

No handles, however constructed, are permitted. The athlete's arms must be outside the saddle

during each heat.

The athlete must cross the finish **beam** on **the** sled.

The finish line beam must be broken by the athlete's helmet.

In case of a crash, the athlete **only** has to cross the finish **beam** in contact with **the** sled in order to be ranked.

10.6.6. Track Conditions during the Race

The track is prepared after agreement among the Jury, the Race Director and the Chief of Track.

In case of snowfall, it shall be made certain that a regularly scheduled race is possible. Particular attention shall be paid to the ice surface at the start up to the start time measurement (50 m), which shall be swept prior to the start of each sled. In particular, the start grooves are to be swept. The track must be swept regularly. The race director must prepare a written protocol for sweeping in consultation with the Jury. The written protocol has to be announced no later than the final Team Captains Meeting.

10.6.7. Track Walks

The times for the track walks are determined after agreement between the Race Director and the Jury, and are disclosed at the first team captains' meeting. Track walks are not allowed outside of these times. Entering the track during a heat is absolutely prohibited.

There are no track walks on race days.

On training days, the athletes are free to choose the start of the track walk from start or finish.

10.6.8. Start

The Jury defines a zone behind the start block that allows the athlete the necessary quiet for his preparations for the start. This zone may only be entered by the athlete, one coach and the Jury.

The start block **must** be stepped upon during the start procedure with one or both feet, and the rear edge of the start block may not be crossed with the complete shoe at any time.

The start line (the first timing point) must be clearly visible.

The athlete shall be present after the call to the start.

The starter clears the track by means of acoustic and optical signals. The athlete at the start must activate the timing device within 30 seconds.

The athletes can accelerate the sled by pushing it.

After the athlete has left the startblock the help from the third party during the start procedure while training and race is prohibited.

10.6.9. Reaction Start

The IBSF will publish a starting procedure protocol.

10.6.10. Reduction

If the number of registered athletes exceeds the capacity of the track, the Jury, in agreement with the Technical Delegate and the Race Director, can reduce the number of participants.

All registered athletes must be allowed to compete in the first heat.

The number of athletes can be reduced before each subsequent race heat.

The starting order does not change in such case.

10.6.11. Interruption or Cessation

The Jury, in consultation with the Technical Delegate, the Race Director and the Chief of Track, can interrupt or stop the race for the following reasons, among others:

- a) damage to the track
- b) weather conditions
- c) failure of the timing system or other technical equipment

After an interruption, the athlete at the start shall be granted a suitable amount of preparation time.

10.6.12. Repetition of a Heat

After a malfunction not caused by the athlete, the heat may be repeated with the authorization of the Jury. The heat may be repeated as soon as the athlete is ready to start.

10.6.13. Replacement Races

In case a race is cancelled, the IBSF may schedule a replacement race at a later date, either on the same track or a different one.

National Federations may register any athlete who is eligible to participate in accordance with rule 4. Participation is not restricted to athletes who were registered for the cancelled race.

10.6.14. Pilot Sleds

The Jury determines the number of pilot sleds. The Organizer is obliged to provide a minimum of three pilot sleds. Only for the World Championships and for the Olympic Winter Games five pilot sleds are required. Before Skeleton races, only Skeleton sleds that meet the specification: height, weight and length outlined in the rules should be used.

If the Jury decides there are an insufficient number of pilot sleds available, the Jury can appoint athletes that are last in the starting order. These athletes start immediately after the pilot sleds, and their pilot heat is also scored as a race heat.

The Race Organizer is fully responsible for the selection of the pilot sleds.

10.6.15. Timing Equipment specifications

- a) Two independent timing systems, each consisting of at least one time measuring device, complete set of light beams and independent power supply, must be available and in operation during a competition (A and B systems).
- b) The A system comprises all light beams for start, start time, four intermediate times, four speeds and finish time. The first interval time corresponds to the start time (50 m). Four interval times must be evenly distributed among the remainder of the track. For TV and Security reasons minimum 3 more light beams have to be set between Intermediate times and Speed traps in longer unmonitored parts of the track.
- c) The B system comprises at least the start and finish light beams to record the heat time. If a track is assigned to held Olympic Winter Games the B system has to be a 100% backup of the A system.
- d) The time of day of both timing systems (A and B systems) must be synchronized and must provide accurate timing of 1/100 of a second.
- e) All times have to be measured as Day Times. Intermediate times and Finish times are calculated by subtraction of Start time from Intermediate time or Start time from Finish time respectively. The result has to be truncated to 1/100 of a second.
- f) Two evaluation and control computers for the timing system must be available and in operation during a competition.
- g) The times measured by both timing systems must be recorded in both evaluation and control computers of the timing system.
- h) In case of failure of the A system it must be possible to switch to the B system without time delay. After this, the times measured by the B system will be used for the continuation of the competition. The times recorded by the A system up to this point will remain valid.

- i) In case of failure of the evaluation and control computer currently operating, it must be possible to switch to the second computer for controlling the timing system within a short time frame.
The ranking valid up to this point is to be saved.
- j) A check list has to be prepared by the Track operators detailing the switching between the two timing systems and the two control computers.
- k) Independently from the computer, the light beam times recorded by each timing system must be printed as daytimes on a corresponding timeline printer.
- l) For external service providers an online data interface must be available through which they can obtain the measured light beam times (e. g. when TV graphics are required)
- m) Uninterrupted power supply must be available for the timing system (time measuring devices and control computers) securing that at least the time of the current sled to the finish is recorded. The power supply of the light beams of the A and B systems must be independent from each other.
- n) Technical Requirements for Reaction Start (in force with the start of the 2025/26 season)
 - a. General Requirements:
 - i. Power supply: 110 - 240V, 16A, 50/60Hz directly at the starting position on both sides of the track
 - ii. Cable crossing at the start section from one side of the track to the other (if the cable cannot be laid under the track, appropriate cable covers must be provided to run the cable around the start area)
 - b. Cabling:
Combination of Fiber and Copper wire connection
 - c. Main system only:
 - i. 2 Fibers within a fiber glass connection (if possible single mode) from the Timing Room to the Start Position for data connection
 - ii. 1 Pair copper wires twisted pair for Start Impulse
 - iii. 2 Pairs copper wires twisted pair from the Timing Room to the Start Position for data connection

Please note that a backup system requires double the cabling mentioned in all points above and should be provided by the tracks.

10.6.16. Time Measurement

The Organizers have to hand over Time measurements and speeds of all participants to the IBSF Coordinator daily during and at the end of the competition.

Times equal to 1/100th of a second are given the same rank.

If two or more athletes achieve the same time in the first, second or third heats, the starting order for these athletes in the second, third and fourth heats respectively shall be determined according to the Bib number. In such a case, the athlete with the highest Bib number is the first to start.

If the number of participants is reduced prior to the final race heat, the eliminated athletes remain in the results with their final ranking. If in the final heat an athlete does not start or is disqualified, they do not receive a final ranking. The remaining athlete(s) move up in the ranking list.

10.6.17. Maintenance of the timing equipment (in place from 2017/18 season on)

- a) For each season the timing equipment must be maintained by a professional company.
- b) A maintenance report will be issued specifying the operations carried out during the maintenance.
- c) Records must be kept of all existing deficiencies which cannot be corrected immediately through the regular maintenance activities (e. g. computer damage).
- d) In the maintenance report it must be confirmed that the timing equipment is ready for use.
- e) The track operator must submit the maintenance report to the IBSF Office prior to the first international competition.

10.6.18. Use of push start facility

Iced or non-iced push start facilities – regardless of whether they are located inside or outside the venue – may not be used during the race days of World Championships, Junior World Championships, Olympic Winter Games or Winter Youth Olympic Games by any athletes who participate in that event. On non-race days during the above Championship and Olympic events the push start facilities can only be used with the approval of the IBSF.

10.7. Parc fermé

A Parc fermé is utilized at every race. The Parc fermé is bordered by barricade fences and/or tape.

- a) The sleds participating in the race must be in the ‘Parc fermé’ (start area), positioned in the spaces assigned to them. All preparatory work performed on the sleds, including mounting the runners, must be completed 45 minutes before the start of the race. The sleds must be uncovered. The sleds must be brought into the Parc fermé with clean runners. After this time point, no work may be performed on either the sleds or the runners. Changing runners and replacing sled parts is also prohibited. Only the person who must bring the sled to the start may enter the Parc fermé.
- b) As soon as the first athlete – after having completed his first heat - returns to the start with his sled on the official transport the Parc fermé will be reopened until 5 minutes prior to the start of the 2nd heat of the same day. The athlete may choose when and how long he wants to stay inside the Parc fermé to perform work in compliance with the Rules. When leaving the Parc fermé the athlete must give notice to the Jury member in charge or an assistant designated by the Jury indicating his starting number.

His sled will be marked in a suitable manner in his presence. Starting from that moment this athlete must not stay anymore in the Parc fermé or enter the latter again. After completion of the work the Parc fermé may only be entered by persons who have to bring the sled to the start.

It is generally prohibited to bring tool boxes or anything similar into the Parc fermé. It is also prohibited to wear gloves or to cover the hands by any other means.

During Parc fermé it is allowed to sand the runners.

The runners can only be sanded using abrasives provided by the IBSF.

The runners must remain mounted on the sled, and the sleds must not be moved away from their assigned space to adjust the runners. The use of any other materials and / or products is prohibited. Violation of this rule is penalized with an immediate disqualification from the race. The Jury can at any time confiscate the abrasives provided by the IBSF, regardless of whether they have been used or not.

Only the Jury, in agreement with the IBSF Material Controller, can give authorization for repair work to be performed on sleds with technical problems.

Between the individual race heats, no further work may be performed without the authorization of the Jury.

If a set of runners is so damaged during a race that immediate repair is not possible, the athlete has the possibility to use a new set of runners, after receiving the authorization of the Jury. The new set of runners is subject to the provisions of the IBSF International Rules.

10.8. Material and Equipment

10.8.1. Sled

In principle, all race heats must be contested with the same sled. If the sled has been damaged beyond immediate repair, a replacement sled may be allowed with the authorization of the Jury. All sleds can be called for a material control by the Jury before the first competition, and can be marked with IBSF labels. Replacement sleds used at the discretion of the Jury must be approved by the Material Controller/Jury immediately after the race heat for which it has been used.

10.8.2. Runners (General)

In all official IBSF races listed on the IBSF-Calendar (OWG, World Championships, Junior World Championships, Continental Championships, WC, AC, EC, NAC, etc.) only IBSF standard runners (standard material) are admitted. The authenticity of the runner steel may be controlled by the IBSF Jury and/or IBSF Material Controller at any time. To define the authenticity of the runner steel, inspections may include the analysis of the composition of the runner material and examination of the hardness of the runner steel. Only geometrical changes to standard IBSF runners through the removal of the original material are allowed. No materials (exceptions runner block and runner post) may be added in any way.

The use of any means of propulsion is prohibited.

Changing runners between race heats held on the same day is only permitted after damage and with the authorization of the Jury.

At the Jury's discretion, runners can be subjected at any moment to inspection with special equipment. In case of inconclusive findings, runners may be seized and sent to a specialized laboratory for further testing.

On the occasion of:

- a) Olympic Winter Games
- b) World Championships

Complete inspections can be conducted prior to the competition.

10.9. Technical Inspections

All sleds and runners participating in the race can be subjected to technical inspections. The Jury decides which sleds and runners are to be inspected and when the inspection is to take place. Inspections of the other equipment can also be conducted. The Jury can assign the members of the IBSF Material Controller to carry out these inspections.

In cases of suspicion, components of the sled can be confiscated and subjected to technical inspections. The inspections can be conducted at a mobile laboratory on the competition site. In this case, the Jury evaluates the laboratory results immediately and takes the appropriate action.

If the technical inspections are conducted after the race at a laboratory outside of the competition site, the inspection results are forwarded to the IBSF Executive Committee. The laboratory in charge must be approved by the IBSF. The procedures used must be in accordance with article 13 of these Rules.

In case the results show proof of a violation against the IBSF International Rules, the IBSF Executive Committee takes the appropriate action. In this case, the National Federation concerned shall bear the costs of the inspection and appraisal. The decisions of the Executive Committee are incontestable.

If it is determined that the IBSF International Rules have been violated, then it automatically results in disqualification from the competition concerned.

10.10. Runner Diameter

The Jury or the IBSF Material Controller checks the diameter of the runners with official IBSF gauges.

The diameter of the runners may not be less than that of the gauge.

10.11. Measurement of Runner Temperatures

The runner temperatures are checked before the start according to the instructions of the Jury. Both runners are checked with an electronic measuring device equipped with a temperature measuring sensor and a display device for temperatures between at least +30° C and -20° C.

The Organizer must provide two electronic measuring devices, one for the Jury and one for the athletes participating in the race.

The temperature of the runners is measured on the side of the runner in the area of the runner post. The measuring sensor shall remain in contact with the runner until the display on the temperature measuring device is stable.

The temperature of the runners that are mounted on the sled being used in the race may exceed the temperature of the reference runner by a maximum of 4° C. If the temperature of the reference runner is less than -14° C, the runners on the sled may have a maximum temperature of -10° C. If an athlete's runner temperature exceeds the limit, another measurement of the temperature of the reference runner and of the runner on the sled shall be made immediately following the first measurement. If the second measurement also shows a temperature that exceeds the limit, it leads to immediate disqualification. This is then registered in the Temperature Measurement Protocol.

The sled must be moved from its assigned place in the start area to the runner temperature measurement station by carrying it (with runners away from the athlete's body). Cooling down the runners by touching them with snow or ice is not allowed.

10.12. Reference Runner

The temperature of the reference runner is measured according to the following procedure.

- a) The reference runner must be made of IBSF standard runner material. It must be hung or otherwise positioned in the open air 45 minutes before the start of the race, in the same climactic weather conditions as the sleds included in the race. When the reference runner is positioned in the open air, it must show a temperature of between +18° C and +22° C.
- b) The exact temperature of the reference runner at the time it was positioned in the open air must be written on a clearly visible board in the start area. The board must also show the air and ice temperatures.
- c) The temperature of the reference runner is measured on the side of the runner in the area of the runner post.
- d) The temperatures shown on the temperature display board are updated as follows:
 - a. The first time, 45 minutes before the start of the race and third heat.
 - b. 10 minutes before the start of the 1st heat, the 2nd heat and the 4th heat. .
 - c. Afterwards, every 15 minutes (This can be omitted for measurements in the parc fermé as soon as all runners were measured within the correct temperature window.)
 - d. In the case of extraordinary climatic conditions (high temperatures), after measuring the runner temperatures the Jury can instruct the teams to place their sleds on the snow or ice immediately before the start.

10.13. Runner Cleaning

The runners are treated and cleaned before the start of the race heats with special cleaning solutions provided by the IBSF.

The IBSF will publish a runner testing Protocol. If any runners are found to be outside the limits set by the Protocol the athlete can be sanctioned by the Jury. The sanctions available to the Jury are outlined in 8.10 of these rules.

10.14. Weight

The weight is checked using a scale.

Weights can be checked at any time upon decision of the Jury.

The sled and the athlete shall be weighed immediately after the conclusion of the race heat, upon request of the Jury. No modifications to the sled or the other equipment may be made.

The first weight test is then made. Each athlete may request a second weight test, if necessary.

For the second test, they have a maximum of 5 minutes to remove snow and ice from the sled.

This occurs under the supervision of the Jury. Help from a third party is not allowed.

The observed weight must be registered in the Weight Protocol.

The combined weight of the sled and the athlete with complete race equipment may not exceed 120 Kg (women: 102 Kg).

The weight of the sled alone may not exceed 45 Kg (women: 38 Kg).

The maximum allowable weight can be reached by attaching ballast weights. The ballast weights must be affixed securely to the frame, base plate or the saddle. Ballast weights on the athlete's body are prohibited.

10.15. Electronic Measuring Devices and Equipment

In the time during which the track is subject to the control of the IBSF (e.g. official training, races, ITP and homologation), electronic or electrical measuring devices or equipment may not be used on the sled, on the athletes or on and beside the track, **with the exception of measurement devices required for Skeleton Mixed Team.** The IBSF or the Jury concerned has the power to grant exceptions such as specific measurements and/or POV recording (complete Skeleton heat), especially during a homologation of a track. In these cases the results of the measurements must be made known to all the participating National Federations. Footage obtained during homologation must be made available to all National Federations.

On and beside the track all coaching devices such as radios, ice thermometers and video recording devices are allowed, but this refers exclusively to such video recording devices, which are not controlled remotely and/or stationary and aren't positioned closely or attached to the track. Each National Federation is responsible to use these devices in a secure and safe manner.

TV cameras belonging to the track or IBSF Stakeholders are not subject to this article.

10.16. Other Equipment

10.16.1. Helmet

Wearing of a safety helmet is mandatory for all competitions, during both training and races. It is the duty and the responsibility of the National Federations to comply with the safety standards.

Only helmets whose shell and padding cover the head and at least the ear area are allowed.

Helmets with spoilers or protruding edges are not allowed.

The bottom edge of the helmet shell must maintain the shape of the helmets normally available on the market. Chin guards and clasps are not allowed to be positioned excessively low.

The chin guard, the visor and the hardware for attaching them are the only protruding elements allowed. These elements cannot, however, have aerodynamic coverings.

For safety reasons, all helmets must have a smooth surface.

A safety helmet

- a) has to be without any additionally attached aerodynamic elements or adhesive tape (except that used to fix the visor or the goggle strap), and
- b) one piece of adhesive tape is allowed on the chin guard with a maximum size of 50mm x 70mm.
- c) One piece of foam padding may be added on the chin strap with adhesive tape, the addition may not exceed a maximum size of 100mm along the length of the strap with 50mm width and 6mm thickness.
- d) On the inside of the chin guard padding may be applied but may not exceed a maximum size of 50mm width with 10mm thickness, according to Figure 8 & 8a.
- e) the helmet shell must not have any concave shape except for the recesses for the visor, and
- f) the padding may protrude a maximum of 3 cm below the shell.

Please see the drawing in article 12.12.

Requirements valid from the season 2026/2027 onwards!

Helmet model must meet ASTM 2040 and EN 1077 (Class A) and be certified under both. In addition, the helmet model must pass an additional specific test under EN 1077 test methods, but at a higher test speed of 6.8 m/s.

10.16.2. Shoes

The use of spikes on the shoes of the athletes is allowed for pushing the sled, as long as the spikes are arranged in brush form.

The maximum diameter of the spikes may not be greater than 1.5 mm, the spikes may not be longer than 5 mm and the minimum amount of spikes per shoe must not be less than 250.

With the exception of the spike plate the shoe must be commercially available and may not be modified.

Shoe coverings are prohibited.
The shoes may be checked by the IBSF at any time.

10.16.3. Clothing

a. Training and Competition Suits:

Training and competition suits with shorts and short sleeves are not allowed. Racing suits shall conform to the natural shape of the body of the Athlete at any time. Insertion or attachment of forms or devices to create different shape is not permitted.

No aerodynamic elements whatsoever may be attached or inserted either outside or under the race suit to create a different shape is not allowed. The surfaces may not be plasticized.

Seams of the competition suits and any clothing worn underneath such as undergarment, etc., may only exist in order to join the portions of the fabric parts and may not have any added materials, neither soft or rigid.

If the racing suit has a hood, it must be worn fully or removed entirely from the suit. The hood should not cover any part of the chin of the athlete.

It is not permitted to be tucked in, rolled, sewed into place or otherwise used in a fashion other than its intended purpose to follow the natural shape of the athlete's head, neck and shoulders.

The racing suits may be checked by the IBSF at any time.

b. Gloves

Gloves must be worn while sliding in the track.

10.17. Awards

10.17.1. IBSF Championships

At official IBSF Championships, with the exception of Junior Continental Championships, the IBSF awards gold, silver and bronze medals to the first, second and third placed athletes. The fourth, fifth and sixth placed athletes receive commemorative medals. The Organizer awards additional honorary prizes to the athletes. At Junior Continental Championships IBSF awards only gold, silver and bronze medals.

10.17.2. Official IBSF Competitions

The Organizer awards honorary prizes to the first to sixth placed athletes with the exception of Junior Continental Championships. At the Junior Continental Championships, the Organizer awards prizes to the first to third placed athletes.

10.18. Awards Ceremony

The awards ceremony should take place as soon as possible after the deadline for submitting protests.

The doping controls and technical inspections may also take place after the awards ceremony.

At all IBSF Championships and official IBSF competitions, the national flags of the first three placed athletes must be hoisted. The national anthem of the winning athlete must also be played.

10.19. Protests

Protests must be made verbally to the Jury immediately or at the utmost 5 minutes after the heat in which that incident happened. Additionally, the grounds for the protest must be submitted in writing to the Jury no more than 20 minutes after the conclusion of the race.

If no verbal declaration of protest is made, no written protest may be subsequently submitted. Only the team captain may submit verbal and written protests. Collective protests are not allowed.

No protests are accepted after the submission deadline passes.

A fee in the value of € 100 shall be paid with the submission of the written protest. If the protest is rejected, the fee is forfeited in favor of the IBSF. Otherwise, the protest fee is returned.

The decision regarding a protest submitted during a race shall be made in a timely manner to allow the athlete affected by the protest to potentially continue to participate in the race.

In cases of protests submitted after the conclusion of the race, the Jury will announce its decision no more than one hour after the submission of the protest, if possible.

The decision of the Jury is determined by a simple majority of votes. If the votes are equal, the Jury President casts the deciding vote. Jury Assistants do not have the right to vote.

The decision of the Jury is final, incontestable and takes effect immediately.

11. RANKING LISTS

11.1. Discipline Ranking List of the Race Series

For the World Cup, Asian Cup, North American Cup, Europe Cup and Youth Series, there are overall ranking lists (Men/Women) issued at the end of the season whereas the best results of each athlete in the particular race series are added up, with the exception of the discipline Skeleton Mixed Team. The winner of the overall WC/AC/EC/NAC & Youth is the athlete with the most points from the competitions in the particular race series (11.3). The first, second and third placed athletes in the overall ranking lists of each series, receive awards.

The Discipline Ranking Lists will be updated after each race.

If the AC, EC and NAC start before the WC the current Discipline Ranking List of the corresponding series will be used to determine the starting order.

11.2. IBSF Discipline Ranking List

Principally only those athletes are listed in an IBSF Discipline Ranking List who are ranked at least in one race, with the exception of the discipline Skeleton Mixed Team.

During the current season, the best results of each athlete are totaled by name for the IBSF Discipline Ranking List, regardless of the race series, in which the results were scored. It is consulted as an adjusted ranking list to determine the quotas for additional World Cup quota spots. The juniors are highlighted.

The number of races scored is equal to the number of World Cup races carried out up to that specific date during the current season.

The IBSF Discipline Ranking List is updated after each race.

The IBSF Discipline Ranking List serves to determine the Nation Quotas for the World Cup after Olympic Winter Games as well as during the Olympic cycle if a Nation hits the Qualification Criterias as described in rule 4.5.1.

The IBSF Discipline Ranking List serves to determine the Starting Order for all IBSF races series of the current season. For the first competition of the race series the start order will be drawn, see Article 10.6.3.

It serves to determine the Nation Quotas for the World Cup races of the following season.

The top-ranked athletes of a nation determine the nation quotas for the World Cup competitions.

If an athlete sits out for a season, the athlete is scored with 50% of his points achieved on the IBSF Ranking List for the first race of the following season.

In cases of equal total points, the following criteria apply to define the position in the IBSF Discipline Ranking List:

- a) In general: The number of races scored is equal to the number of World Cup races carried out up to that specific date during the current season. The athlete with the highest individual number of points among all races considered is in the lead.
- b) In case of a tie according to item 1, the race immediately preceding and considered at the time of the issue of the IBSF ranking list is decisive, regardless of the number of points. This means that the athlete is in the lead, whose latest for the IBSF ranking considered race is the most recent.
- c) In case that the athlete concerned have obtained a result in the same most recent race considered according to item 2, the athlete with the better placement in the corresponding race is in the lead.
- d) In case of a tie according to item 3 (only possible if the athlete have an ex-aequo placement in the corresponding race), the procedure described in item 2 must be repeated, taking into account the next immediately preceding race.
- e) In case of a tie according to item 4, the position of the athlete concerned for the draw of the starting order of the race will be decided by lot.

11.3. IBSF Ranking List – Points

<u>World-Cup</u>	
<i>Rank</i>	<i>Points</i>
1	225
2	210
3	200
4	192
5	184
6	176
7	168
8	160
9	152
10	144
11	136
12	128
13	120
14	112
15	104
16	96
17	88
18	80
19	74
20	68
21	62
22	56
23	50
24	45
25	40
26	36
27	32
28	28
29	24
30	20
31	18
32	16
33	14
34	12
35	10
36	9
37	8
38	7
39	6
40	5

North American-/Europe-/Asian-Cup/Junior World Championships				
Rank	21 and more participants drawn for the race	from 16 to 20 participants drawn for the race	from 11 to 15 participants drawn for the race	from 6 to 10 participants drawn for the race
	100%	75%	50%	
1	120	90	60	35
2	110	83	55	25
3	100	75	50	20
4	92	69	46	16
5	84	63	42	12
6	76	57	38	9
7	68	51	34	7
8	62	47	31	5
9	56	42	28	3
10	50	38	25	1
11	46	35	23	
12	42	32	21	
13	38	29	19	
14	34	26	17	
15	30	23	15	
16	28	21		
17	26	20		
18	24	18		
19	22	17		
20	21	16		
21	20			
22	19			
23	18			
24	17			
25	16			
26	15			
27	14			
28	13			
29	12			
30	11			
31	10			
32	9			
33	8			
34	7			
35	6			
36	5			
37	4			
38	3			
39	2			
40	1			

Youth Competitions	
<i>Rank</i>	<i>Points</i>
1	75
2	65
3	55
4	50
5	45
6	40
7	38
8	36
9	34
10	32
11	30
12	28
13	26
14	24
15	22
16	20
17	18
18	16
19	14
20	12
21	10
22	9
23	8
24	7
25	6
26	5
27	4
28	3
29	2
30	1

12. SKELETON SLEDS WITH DRAWINGS

12.1. Basic Principles

- a) Skeletons are sleds with two runners that are used in races that are carried out on iced tracks.
- b) To propel the sled, only the pushing force of the athlete, when starting, and the force of gravity are allowed.
- c) No hydraulic, pneumatic, electrical or energy conversion devices of any kind are allowed on the sled.
- d) Sled manufacturers are responsible for ensuring that the sled is constructed in such a way that it can withstand the strain of repeated runs on bob tracks without damage.
- e) The sled must be constructed in such a way that the runners may be adjusted without removing the sled from the assigned space (standing) during the races.
- f) In official competitions, after completion of the work in the Parc Fermé, the sled's specifications may no longer be modified in any way (exception in case of accidental damage).
- g) The Jury and / or the IBSF Material Controller must be able to check the specifications of all construction elements.

12.2. Construction

- a) The Skeleton sled must be composed of the following components:
 - a. Frame
 - b. Saddle
 - c. Saddle plates
 - d. Cowling
 - e. Runners
 - f. Bumpers
- b) The dimensions indicated in the drawings are compulsory.
- c) The maximum weight of the sled is 38 Kg for Women and 45 Kg for Men. (Rule 10.14)
- d) Protruding items that could cause injury are prohibited.
- e) Fairings, spoilers, and aerodynamic elements (not including the cowling) are prohibited.
- f) Any additional components of the sled construction must be fixed securely to the Frame, Cowling Saddle plate or Saddle.
- g) No sprung, rubber, rubber-like or energy absorbing materials or elements may be used in the sled components or in the mechanical joints between them.
 - Exceptions:
 - mounting locations of the cowling on to the construction frame (maximum of 50 mm length x 50 mm width for each mounting location)
 - openings of the cowling for bumpers and stands
 - coverings on the supporting surface and the saddle
 - filling up hollow spaces under the supporting surface (Figure 6)
 - between the construction frame and the cowling

h) It is accepted that the runner loaded in the construction frame could cause a sprung effect.

i) For the purpose of the IBSF, the term "steel" means an iron-carbon alloy with an iron (Fe) content of more than 50% by weight, or an alloy that reacts positively to the IBSF-approved test device.

12.3. Dimensions (Figures 1, 2 & 3)

- a) Sled length: 800 – 1200 mm
- b) Overall sled height: 80 – 200 mm (as prepared for the race)
- c) Runner gauge: 340 – 380 mm from runner center to runner center

12.4. Frame (Figures 1, 2, 4 & 7)

The Frame consists of the following components:

- a) 2 x Longitudinal bars
 - a. Minimum rectangular cross-sectional area along the entire length must be 30mm x 5mm (Figure 4).
 - b. Material – Steel
- b) 2 x Transverse bars
 - a. Minimum rectangular cross-sectional area along the entire length must be 25mm x 3mm (Figure 4).
 - b. Material – Steel
- c) Runner blocks / Support (if separate to bars)
 - a. Material - Steel
- d) 2 x Runner post guide
 - a. Maximum of one Runner post guide on each of the Longitudinal bars.
 - b. Maximum dimensions 25mm wide x 45mm Long.
 - c. Material - Steel
- e) Connections
 - a. The corner connecting joints must attach the frame's bars firmly and rigidly to each other or to the runner supports. These joints may be welded or bolted with a minimum of 2 bolts per joint. There may be a vertical separation between the transverse bar and the longitudinal bar of not more than 2 mm (Figure 7).
 - b. The front transverse bar must be attached in the region of the runner support. The maximum permitted distance between the front end of the runner support and the transverse bar is 80 mm (Figure 1). The rear transverse bar must be attached in the region of the runner support. The maximum permitted distance between the rear end of the runner support and the transverse bar is 30 mm (Figure 1).
 - c. Where a hole exists, and the minimum rectangular cross-sectional area is not achieved the hole must be filled. The hole must be filled with a steel bolt and have a threaded connection to the construction frame.

12.5. Saddle and Saddle Plates (Figures 1, 2 & 3)

The saddle is the support for both the push and descent phase of the run. It must hold the athlete in a safe and supportive manner throughout the run.

- a) Material – Metal
- b) Composed of a left- and right-hand sides that do not affect each other. The horizontal lateral movement allowable is 3mm each side measured between the saddle plate and the longitudinal frame rail at their connection points.
 - a. Minimum gap between left- and right-hand sides is 100mm at the level of the supporting surface of the sled (Figure 1).
- c) The metal saddle and connection bolts must have a padding (including tape) with a maximum overall thickness is 30mm.
- d) Pushing aids or handles are prohibited, including unregulated prosthetic devices.
- e) The athlete's arms must be outside of the saddle during the run.
- f) The length of the saddle is defined by the point where the athlete holds the saddle when in the prone position in sliding, the saddle must not extend beyond this point.
 - a. Each side of the saddle may have a maximum cumulative opening of 450 mm. The maximum distance allowed for any opening is 200 mm (Figure 2). The saddle has to be fixed mounted to the saddle plates.
 - b. The lowest point, front and back, of the saddle (in the longitudinal axis) may not be higher than the supporting surface

12.6. Cowling and Supporting Surface (Figures 1, 3 & 6)

The Cowling is the component used to cover the frame.

- a) 1 piece
- b) Convex in shape (maximum allowable concavity over 300mm is 3mm)
 - a. Exception – within an area of 80mm from the front edge (Figures 1 & 3).
 - b. Multiple depressions or protrusions are prohibited.
- c) Connection to the frame
 - a. Secure bolting or locking mechanism such that it is easily removable for sled checks.
- d) The top edge of the cowling defines the supporting surface.
 - a. Hollow spaces in the cowling under the supporting surface may be filled with padding (Figure 6).
 - b. The supporting surface must not have any localised depressions or protrusions greater than 10mm in any given 300mm.

Exceptions:

- Depressions within an area of 80mm from the front edge and 200mm maximum width (Fig. 1 + 3)

12.7. Runners (Figure 5)

- a) 2 runners are used to contact the ice track.
- b) The runners must be mounted directly to the frame or runner blocks.

- c) Every runner must be constructed from one solid piece of the standard material according to IBSF specifications and must not exceed 320 Brinell (HB). The standard material is produced and distributed by a factory designated by the IBSF.
- d) The material is supplied as polished round bars with a diameter of 16 mm (h9 tolerance class) and a length of 1000mm or 1200mm, $-0/+50$ mm. The material is always supplied with markings. These markings must always be present on the runners and must not be altered in any way.
- e) Runner material maybe bent to form a runner shape and the addition of runner blocks and a post to mount to the frame are permitted. The depths of the millings and grooves, measured from the surface of the ice, must not be greater than 2 mm.
- f) Runner blocks must be welded to the runner.
- g) Runner posts must be welded or bolted to the runner.
- h) All other types of treatment are forbidden, including those which cause even only a local variation of the physical characteristics (*) and / or the composition and / or the structure of the material.
- i) No plating and/or coating is allowed
- j) The diameter of the steel runner must be 16 mm along its entire length right up to the joints with the runner supports and the runner posts (a shortfall of up to 0.80 mm is permissible).
- k) By order of the Jury the runners maybe confiscated for in-depth inspection subject to protocol. Note (*):

The term “physical” is to be understood as a global term which comprises all specific terms like, for example, “mechanical”, “tribological”, “electromagnetic”, etc.

12.8. Bumpers (Figure 1, 2 & 3)

- a) Bumpers must be mounted on the front and rear of the sled on both the left and right-hand sides of the sled.
- b) 2 x Front bumpers
 - a. Material – Steel
 - b. The minimum radius must be 6 mm (rectangular or cylindrical) measured with a radius template (exception – mounting onto the frame).
 - c. Minimum permitted distance between the outside edge of the runner and the outside edge of the front bumper is 70mm. The minimum permitted length of each front bumper is 120mm.
 - d. The front bumpers may only protrude a maximum of 15mm above the supporting surface.
 - e. The bumper must not extend 20mm inwards from the inside face of the runner.
- c) 2 x Rear bumpers
 - a. Material – Steel
 - b. The minimum radius must be 6 mm (rectangular or cylindrical) measured with a radius template (exception – mounting onto the frame).

-
- c. The minimum permitted distance between the outside edge of the runner and the outside edge of the rear bumper is 35mm. The minimum permitted length of the rear bumper is 80mm.
 - d. They may not protrude laterally beyond the front bumpers.
 - e. If the rear bumper is mounted in the direction of the middle of the sled, the outside dimension must increase in a straight line to the front bumper.
- d) Worn bumpers will be permitted with a minimum **width** of 11mm.

12.9. Drawings

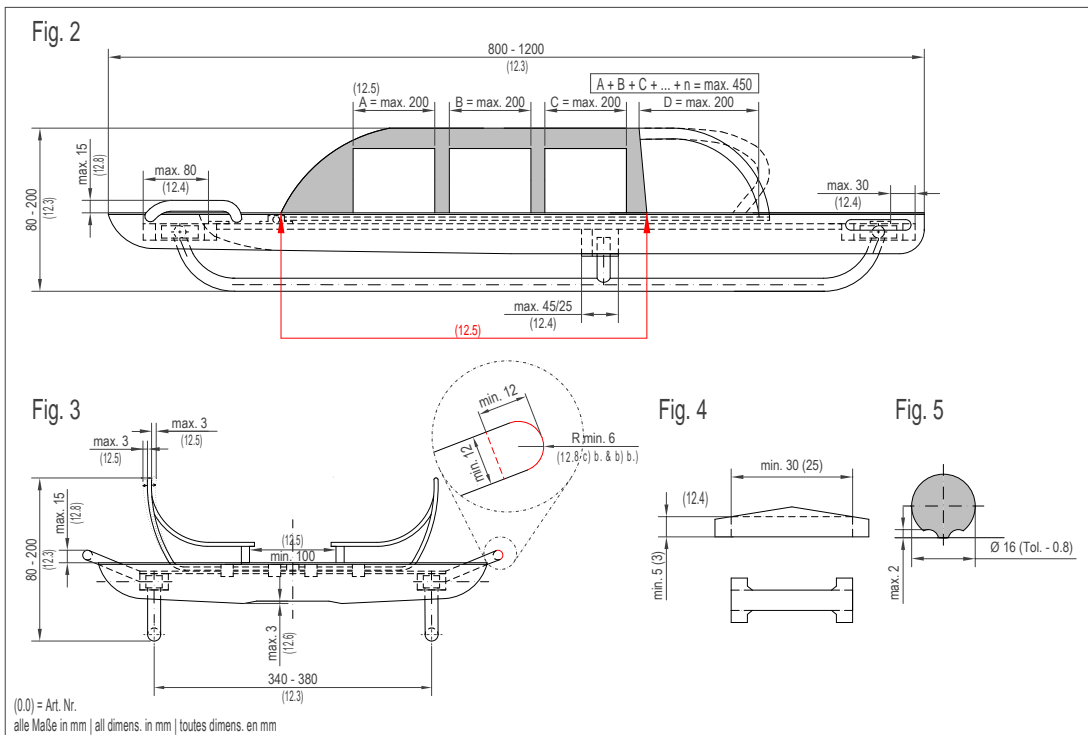
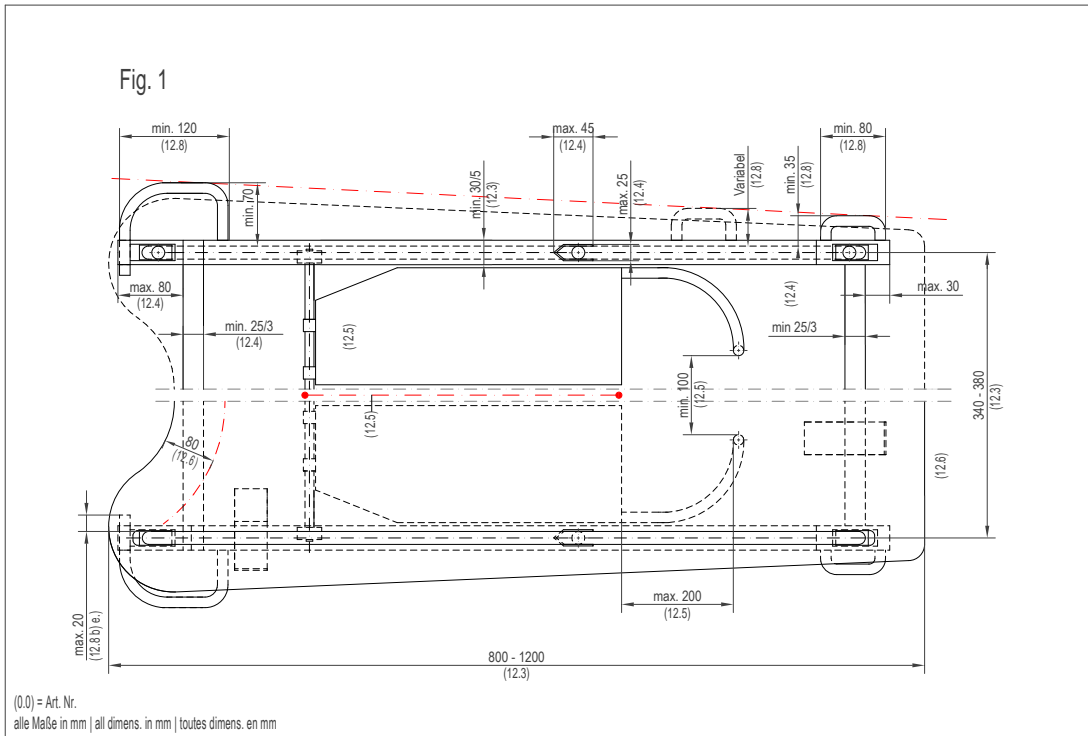

Fig. 6

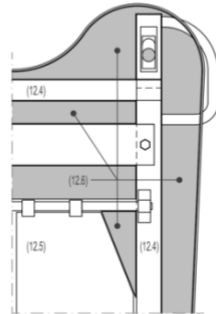
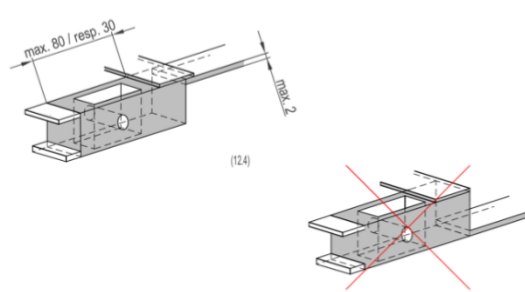

Fig. 7



(0.0) = Art. Nr.
alle Maße in mm | all dimens. in mm | toutes dimens. en mm

Fig. 8
inside view

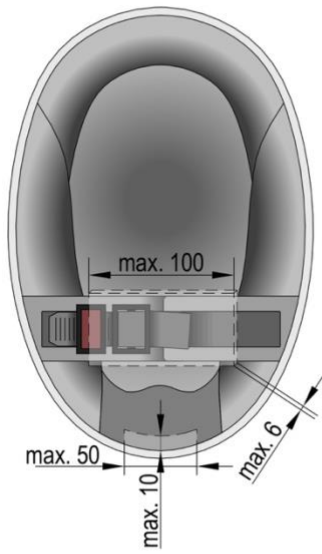
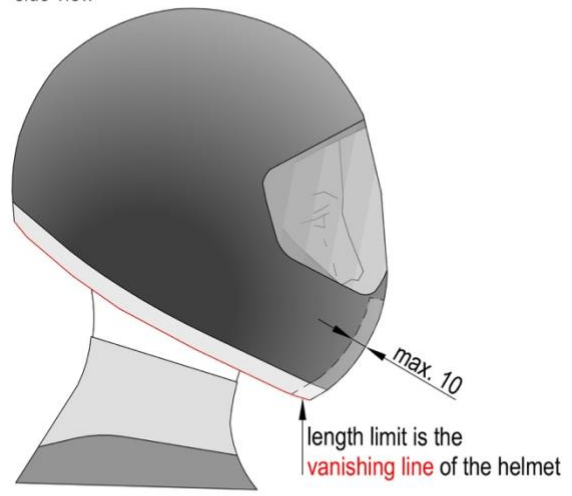
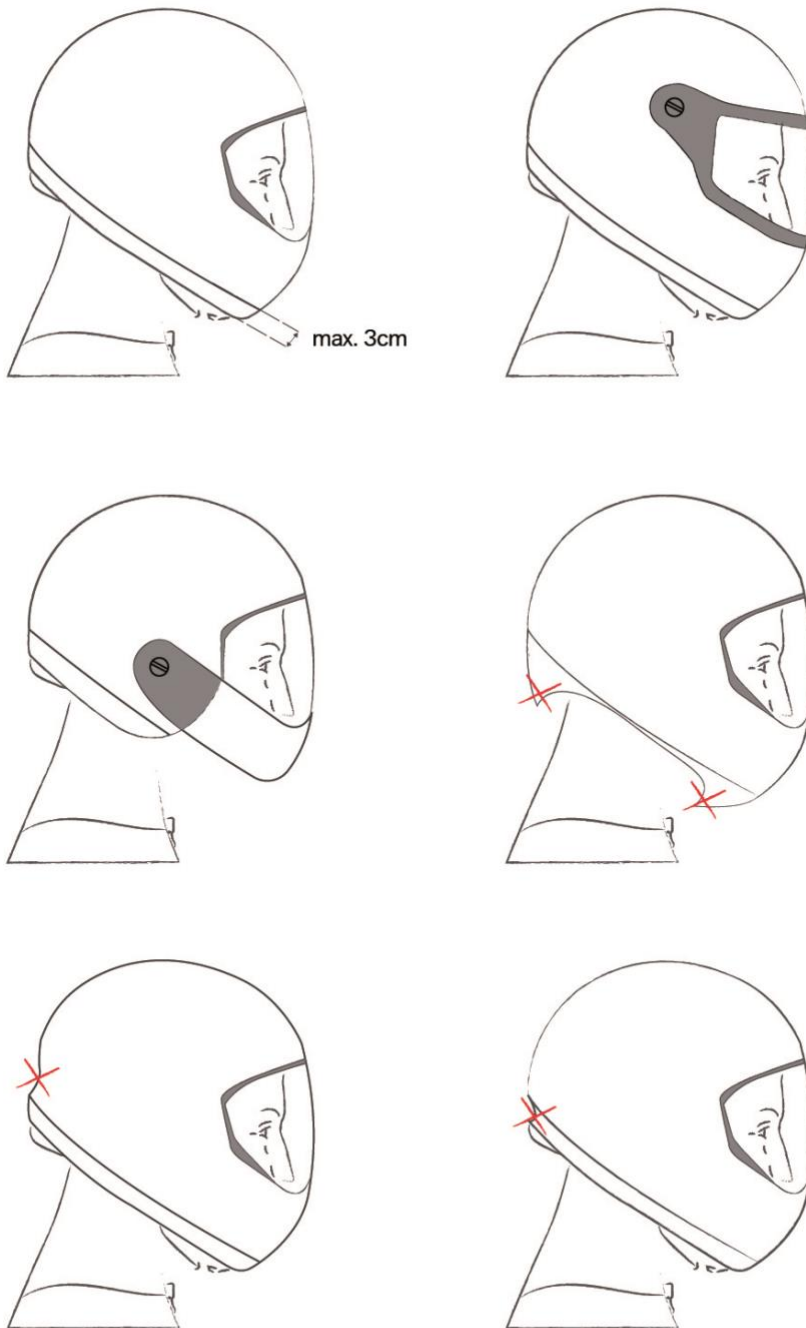



Fig. 8a
side view



(0,0) = Art. Nr.
alle Maße in mm | all dimens. in mm | toutes dimens. en mm

12.10. Equipment



-  concave form allowed
-  no aerodynamic modification allowed

Drawing for article 10.16.1

13. MATERIAL SEIZURE

13.1. Procedure for the seizure of sled components for conformity tests

Empowered by the Jury and in the presence of at least one of its members, the IBSF Material Controller responsible directs the official representative of the Federation to which the sled belongs to remove or disassemble the component(s) to be tested.

13.2. The Form

Upon collecting the component(s), the IBSF Material Controller will fill in a form drawn up in six copies, stating:

- a) general data of the team / athlete whose sled is being tested
- b) the name of the competition and the venue
- c) the date and time
- d) a description of the component(s) taken
- e) the type of test(s) the laboratory is required to perform
- f) a blank space for entering the laboratory analysis results

The following people will sign the form:

- a) the Jury President
- b) the representative of the IBSF Material Controller
- c) the team captain or official representative of the Federation to whom the sled belongs

The five copies of the form will be sent to the following:

- a) one copy to the Jury President
- b) one copy to the IBSF President (via the Secretary General)
- c) one copy to the team captain or official representative of the Federation to whom the sled belongs
- d) two copies to the laboratory, together with the container holding the component(s) to be tested

By returning one of the two copies of the form to the IBSF Secretary General, the laboratory confirms that it has received the container undamaged.

13.3. The Container

The seized components will be sealed in a container.

13.4. Remarks

The IBSF bears the costs of the laboratory analysis. In case of positive analysis results, the IBSF can order the costs to be reimbursed by the Federation to whom the sled belongs.

PROTOCOL FOR SEIZURE OF SLED COMPONENTS FOR CONFORMITY TESTS

Place: _____ Date: _____ Time: _____ Competition: _____

Event: _____ Nation: _____

Description of component/s taken: _____

Test/s required: _____

Name of Laboratory: _____

Laboratory result: _____

President of Jury Material Controller National Federation

Name: _____ Name: _____ Name: _____

Signatures: _____

The Laboratory _____ in the person of Mr. _____

acknowledges receipt of the official container bearing unbroken seals, from Mr.

on (date) _____ at (time) _____

Stamp: _____
(signature)

14. ADVERTISING GUIDELINES AND DRAWINGS

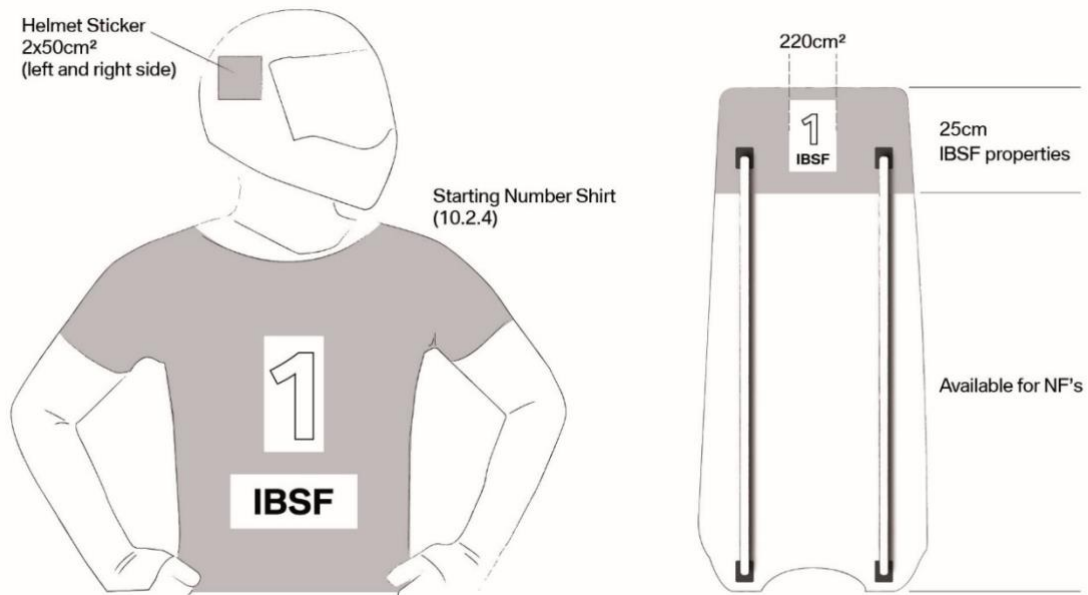

IBSF properties / Fläche für IBSF

Available for NF's / Den NV zur Verfügung stehend

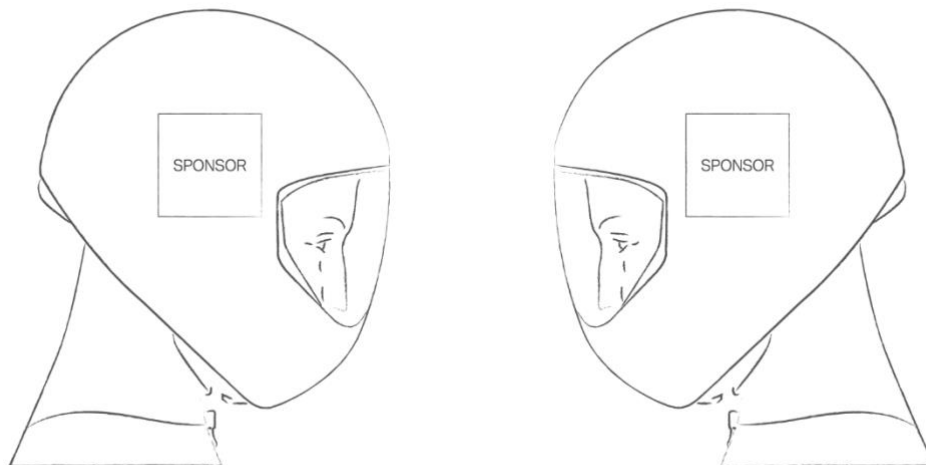

IBSF properties: helmet (bob & Skeleton)

Left and right side of the helmet, as close as possible to the visor

Size: 50cm²

15. FINAL CLAUSES

15.1. Coming into Force

This edition comes into force on October 1st, 2024.

15.2. Modifications

The IBSF Executive Committee determines modifications to the IBSF International Rules.

15.3. Interpretation

If an article in these Rules should be ambiguously defined so that multiple interpretations are possible, the interpretation should be used that matches the underlying meaning for which the article was written.

16. GLOSSARY

Term / Abbreviation	Definition
DSQ – Disqualified	A ruling by officials that an athlete or team has broken or failed to observe the rules of the sport and cannot be considered for placing in the competition.
Unsportsmanlike behaviour	Unsportsmanlike behaviour includes in particular improper behaviour, bad or offensive language, not showing fairness or respect to other people and/or causing intentional damage.
DQB - Disqualification for unsportsmanlike behaviour	A disqualification due to any violation of the Olympic Charter, of the World Anti-Doping Code, or any other serious breach of applicable regulations issued by the IBSF and the IOC.
DNS – Did Not Start	If an athlete or team has been drawn for the competition but did not start.
DNF – Did Not Finish	If an athlete or team does not cross the finish timing eye.
Member = National Federation = Nation	These three terms are used synonymously describing the National Federations that are Members of the IBSF representing their country internationally in bobsleigh and/or Skeleton sport (IBSF events). They have to comply with IBSF Rules and Regulations.
Congress	The Congress is the highest authority of the IBSF, and it consists of the Delegates nominated by the Members and the Executive Committee.
Quota	A restriction that limits the number of participants in any IBSF competition and Olympic Winter Games.
Ranking List	A listing of athletes/teams according to IBSF system of rating for each series.
to be ranked	All athletes that finish the race without being classified as DNS, DNF, DSQ or DQB are being ranked in a race.
International Jury License	A formal permission from IBSF to a person to take part in the official IBSF competitions as a Jury President or Jury Member. To obtain it the candidate has to pass the International Jury Exam.
Abrasive	Material (e.g. sandpaper) used to polish the runners.
Gauge	An instrument used to measure the runner radius.
Electronic Measuring Devices	Any instruments used to measure speed, temperature, G-force etc.
OWG	Olympic Winter Games
WC	World Cup
WCH	World Championships
AC	Asian Cup
EC	Europe Cup
ECH	European Championships
NAC	North American Cup
ITP	International Training Period