



INTERNATIONAL BOBSLEIGH RULES 2024

In order to allow easy traceability of the changes compared to 2023 we have highlighted them in yellow.

Table of Contents

1.	IBSF COMPETITIONS	7
1.1.	OLYMPIC WINTER GAMES	7
1.1.1.	<i>Olympic Winter Games</i>	7
1.1.2.	<i>Winter Youth Olympic Games</i>	7
1.2.	CHAMPIONSHIPS	7
1.2.1.	<i>World Championships</i>	7
1.2.2.	<i>Junior World Championships</i>	7
1.2.3.	<i>Continental Championships</i>	7
1.2.3.1.	<i>European Championships</i>	7
1.2.4.	<i>Junior Continental Championships</i>	7
1.2.4.1.	<i>Junior European Championships</i>	7
1.2.5.	<i>Para World Championships</i>	7
1.2.6.	<i>Summer Push World Championships</i>	7
1.3.	OFFICIAL IBSF COMPETITIONS	7
1.3.1.	<i>World Cup Competitions</i>	7
1.3.2.	<i>Intercontinental Cup Competitions</i>	7
1.3.3.	<i>Asian Cup, Europe Cup and North American Cup Competitions</i>	7
1.3.4.	<i>IBSF Sanctioned Competitions</i>	7
1.3.5.	<i>Para World Cup Competitions</i>	7
1.3.6.	<i>Youth Competitions</i>	7
1.3.7.	<i>Summer Push Competitions</i>	7
1.4.	TEST COMPETITIONS AND INTERNATIONAL TRAINING PERIOD	7
1.5.	ALLOCATION OF COMPETITIONS	9
1.6.	GENDER AND NUMBER	9
2.	DISCIPLINES	9
2.1.	MEN'S BOBSLEIGH	9
2.1.1.	<i>2-man Bobsleigh</i>	9
2.1.2.	<i>4-man Bobsleigh</i>	9
2.2.	WOMEN'S BOBSLEIGH	9
2.2.1.	<i>2-woman Bobsleigh</i>	9
2.2.2.	<i>Women's Monobob</i>	9
2.3.	TEAM COMPETITION	9
2.3.1.	<i>Bobsleigh/Skeleton Mixed Team</i>	9
2.4.	OTHER DISCIPLINES	9
2.4.1.	<i>Youth Monobob (see IBSF Youth Rules)</i>	9
2.4.2.	<i>Para Bobsleigh (see IBSF Para Bobsleigh Rules)</i>	9
2.4.3.	<i>Summer Push (see IBSF Summer Push Rules)</i>	9
3.	ADMISSION	10
4.	RIGHT TO PARTICIPATE IN COMPETITIONS	10
4.1.	OLYMPIC WINTER GAMES	10
4.2.	WORLD CHAMPIONSHIPS	10
4.2.1.	Requirements for participation in the World Championships:	11
4.3.	JUNIOR WORLD CHAMPIONSHIPS	11
4.3.1.	Requirements for participation in the Junior World Championships:	11
4.4.	CONTINENTAL CHAMPIONSHIPS	12
4.4.1.	Requirements for participation in the Continental Championships:	12
4.4.2.	Requirements for participation in the Junior Continental Championships:	12
4.5.	WORLD CUP AND INTERCONTINENTAL CUP	13
4.5.1.	World Cup	13
4.5.2.	<i>Intercontinental Cup</i>	13
4.5.3.	Requirements for participation in the World Cups and Intercontinental Cups:	13
4.6.	ASIAN CUP, EUROPE CUP AND NORTH AMERICAN CUP	13
4.7.	IBSF SANCTIONED COMPETITIONS	14

5.	EVENT	14
5.1.	GENERAL.....	14
5.2.	COSTS.....	14
5.3.	TRACK.....	14
5.4.	EVENT ANNOUNCEMENTS AND INVITATIONS.....	14
5.5.	ORGANIZING COMMITTEE AND RACE DIRECTOR.....	15
5.6.	TECHNICAL EQUIPMENT.....	15
5.7.	LIABILITY INSURANCE.....	16
5.8.	FURTHER OBLIGATIONS OF THE ORGANIZER.....	16
6.	JURY AND TECHNICAL DELEGATES	16
6.1.	JURY LICENSE.....	16
6.2.	LICENSE FOR MATERIAL CONTROLS.....	17
6.3.	NOMINATION.....	17
6.3.1.	<i>Olympic Winter Games</i>	17
6.3.2.	<i>World Championships</i>	17
6.3.3.	<i>Junior World Championships, Continental Championships, World Cup and Intercontinental Cup</i>	17
6.3.4.	<i>Asian Cup, Europe Cup and North American Cup</i>	17
6.3.5.	<i>IBSF Sanctioned Competitions</i>	17
6.4.	AUTHORITY.....	18
6.4.1.	Jury	18
6.4.2.	<i>Technical Delegates</i>	18
6.4.3.	<i>Attendance</i>	18
6.4.4.	<i>Expenses</i>	19
6.4.5.	<i>Authority to Inspect</i>	19
6.4.6.	<i>Special Decisions</i>	19
7.	RACE DIRECTOR	19
7.1.	APPOINTMENT.....	19
7.2.	DUTIES.....	19
8.	GENERAL REGULATIONS	20
8.1.	SPORTING YEAR.....	20
8.2.	LIABILITY.....	20
8.3.	AMATEURISM RULES.....	20
8.4.	LICENSES.....	20
8.5.	INSURANCE.....	21
8.6.	ENTRIES	21
8.7.	ACCEPTANCE OF THE INTERNATIONAL RULES.....	21
8.8.	TRACK RECORDS AND START RECORDS.....	21
8.9.	DOPING CONTROLS.....	22
8.10.	RULE VIOLATIONS.....	22
8.10.1.	<i>Athlete Support Person Rule Violations</i>	22
8.10.2.	<i>Prohibited Association</i>	23
8.10.3.	<i>Burden of Proof</i>	23
8.11.	SPONSORSHIP AND ADVERTISING.....	23
8.12.	TRADEMARKS ON EQUIPMENT.....	23
8.12.1.	<i>IBSF Properties</i>	23
8.12.2.	<i>Freely Available Advertising Areas</i>	23
8.13.	GENERAL PRINCIPLES.....	23
9.	MEDICAL SERVICE AT THE TRACK	24
9.1.	RACE MEDICAL.....	24
9.2.	TEAM MEDICAL/DOCTOR.....	25
9.3.	EVACUATION OF INJURED ATHLETES.....	25
10.	THE COMPETITION	26
10.1.	OFFICIAL TRAINING.....	26

10.1.1.	<i>Olympic Winter Games and World Championships</i>	27
10.1.2.	Continental Championships, World Cup and Intercontinental Cup	27
10.1.3.	<i>Junior World Championships, Asian Cup, Europe Cup and North American Cup</i>	27
10.1.4.	<i>IBSF Sanctioned Competitions</i>	28
10.1.5.	<i>Changes to Official Training</i>	28
10.2.	STARTING ORDER DURING TRAINING.....	28
10.2.1.	<i>Olympic Winter Games:</i>	28
10.2.2.	<i>World Championships:</i>	28
10.2.3.	<i>All other official IBSF races according to rule point 1.3:</i>	28
10.3.	TRACK CONDITIONS DURING TRAINING	29
10.4.	START GROOVES	29
10.5.	REPLACEMENT OF ATHLETES.....	29
10.6.	THE RACE.....	30
10.6.1.	<i>Race Heats</i>	30
10.6.2.	<i>Starting Order</i>	30
10.6.3.	Starting Order System	30
10.6.4.	<i>Start Number</i>	32
10.6.5.	<i>Teams and Manner of Driving</i>	32
10.6.6.	<i>Track Conditions during the Race</i>	32
10.6.7.	<i>Track Walks</i>	32
10.6.8.	<i>Start</i>	33
10.6.9.	<i>Reduction</i>	33
10.6.10.	<i>Interruption or Cessation</i>	33
10.6.11.	<i>Repetition of a Heat</i>	33
10.6.12.	<i>Replacement Races</i>	33
10.6.13.	<i>Pilot Sleds</i>	34
10.6.14.	<i>Timing Equipment specifications</i>	34
10.6.15.	<i>Time Measurement</i>	35
10.6.16.	<i>Maintenance of the timing equipment (in place from 2017/18 season on)</i>	36
10.6.17.	<i>Use of push start facility</i>	36
10.7.	PARC FERMÉ.....	36
10.8.	MATERIAL AND EQUIPMENT	36
10.8.1.	<i>Sled</i>	36
10.8.2.	<i>Runners</i>	37
10.9.	TECHNICAL INSPECTIONS.....	37
10.10.	RUNNER RADIUS	39
10.11.	MEASUREMENT OF RUNNER TEMPERATURES	39
10.12.	REFERENCE RUNNER.....	40
10.13.	RUNNER CLEANING.....	40
10.14.	WEIGHT	40
10.15.	ELECTRONIC MEASURING DEVICES AND EQUIPMENT.....	41
10.16.	OTHER EQUIPMENT	42
10.16.1.	<i>Helmet</i>	42
10.16.2.	<i>Shoes</i>	42
10.16.3.	<i>Clothing</i>	42
10.16.4.	Protection vest	42
10.17.	AWARDS.....	42
10.17.1.	IBSF Championships	42
10.17.2.	Official IBSF Competitions	43
10.18.	AWARDS CEREMONY.....	43
10.19.	PROTESTS	43
11.	RANKING LISTS	43
11.1.	DISCIPLINE RANKING LIST AND DISCIPLINE COMBINED RANKING LIST OF THE RACE SERIES	43
11.2.	IBSF DISCIPLINE RANKING LIST AND IBSF COMBINED RANKING LIST.....	44
11.3.	IBSF RANKING LIST - POINTS	46

12.	BOBSLEIGH CONSTRUCTIONS WITH DRAWINGS	47
12.1.	PRINCIPLES AND PROPERTIES	47
12.1.1.	<i>Purpose of the Rules of 12.1</i>	47
12.1.2.	<i>Principles</i>	47
12.1.3.	<i>Bobsleigh Properties</i>	48
12.1.3.1.	Bobsleigh Functional Dimensions	48
12.1.3.1.1.	Gauge (centre to centre of opposite runners).	48
12.1.3.1.2.	Axle base	48
12.1.3.2.	Bobsleigh Miscellaneous Properties	48
12.1.3.2.1.	Bobsleigh Suspension	48
12.1.3.2.2.	Bobsleigh Brakes	48
12.1.3.2.3.	Ballast	48
12.2.	BOBSLEIGH CONSTRUCTION AND FUNCTIONING	49
12.2.1.	<i>Purpose of Rules of 12.2</i>	49
12.2.2.	<i>General Structure and Functioning</i>	49
12.2.2.1.	Articulation	49
12.2.2.1.1.	Transversal Division	49
12.2.2.1.2.	Pivotal Connection	49
12.2.2.1.3.	Longitudinal Pivot Axis	49
12.2.2.1.4.	Cowling division	50
12.2.3.	<i>Frame and Running Gear</i>	50
12.2.3.1.	Purpose of the Rules of 12.2.3	50
12.2.3.2.	General Stipulations Frame	50
12.2.3.3.	Front Portion of the Frame	50
12.2.3.3.1.	Steering mechanism	51
12.2.3.3.2.	Front Axle	52
12.2.3.3.3.	Front Axle Leaf Spring	52
12.2.3.3.4.	Front Runner Carriers	53
12.2.3.4.	Rear Portion of the Frame	55
12.2.3.5.	Intentionally left blank	55
12.2.3.6.	Rear Axle	55
12.2.3.6.1.	Intentionally left blank	56
12.2.3.6.2.	Runner Carriers	56
12.2.4.	<i>Cowling</i>	58
12.2.4.1.	Purpose of 12.2.4	58
12.2.4.2.	General Cowling Stipulations	59
12.2.4.3.	Cowling Dimensions	59
12.2.4.3.1.	Cowling Width, 2-man Bobsleigh	59
12.2.4.3.2.	Cowling Width, 4-man Bobsleigh	59
12.2.4.3.3.	Inside Cowling Width 2-man and 4-man Bobsleigh	59
12.2.4.3.4.	Cowling Height	59
12.2.4.3.5.	Cowling Side Region	59
12.2.4.3.6.	Cowling Miscellaneous	60
12.2.4.4.	Cowling Shapes	60
12.2.4.4.1.	Purpose of 12.2.4.4	60
12.2.4.4.2.	Convex Surfaces	60
12.2.5.	<i>Connection between Frame and Cowling</i>	61
12.2.5.1.	Purpose of 12.2.5	61
12.2.5.2.	Definition of Connection between Cowling and Frame	61
12.2.5.3.	General Stipulations	61
12.2.5.4.	Locations of points of mounting of Cowling to Frame	62
12.2.5.5.	Freedom of Movement of Cowling relative to Frame	62
12.2.5.6.	Materials used in Cowling to frame Connection	63
12.2.6.	<i>Bumpers</i>	63
12.2.6.1.	Purpose of 12.2.6	63
12.2.6.2.	General Stipulations	63
12.2.6.3.	Bumper Positions and Dimensions	63
12.2.6.4.	Maximally - 760 mm (2-man/2-woman and 4-man bobs). Bumper Shapes	64
12.2.6.5.	Transitions to Cowling	64
12.2.7.	<i>Runners</i>	65

12.2.7.1.	Purpose of 12.2.7.....	65
12.2.7.2.	Runner material	65
12.2.7.3.	Runner Treatment.....	65
12.2.7.4.	Runner Dimensions.....	65
12.2.7.5.	Connection between Runners and Runner Carriers.....	66
12.2.7.6.	Runners Miscellaneous	67
12.2.8.	<i>Detachable, moveable and/or adjustable parts</i>	67
12.2.8.1.	Purpose of 12.2.8.....	67
12.2.8.2.	Brakes	67
12.2.8.3.	Push bars	68
12.2.8.4.	Foot Rests and Hand Holds	68
12.2.8.5.	Steering ropes and Steering handles	68
12.2.8.6.	Carrying Bars.....	68
12.2.8.7.	Padding materials.....	69
12.3.	MISCELLANEOUS.....	69
12.3.1.	<i>Purpose of 12.3</i>	69
12.3.2.	<i>Principles and Properties</i>	69
12.3.2.1.	Applicability	69
12.3.2.2.	Tolerances and Limits	69
12.3.2.2.1.	Use of measuring equipment	69
12.3.2.2.2.	Quality of testing equipment	70
12.3.3.	<i>List of Drawings and Figures</i>	70
12.4.	DRAWINGS.....	72
13.	MATERIAL SEIZURE	91
13.1.	PROCEDURE FOR THE SEIZURE OF SLED COMPONENTS FOR CONFORMITY TESTS.....	91
13.2.	THE FORM	91
13.3.	THE CONTAINER.....	91
13.4.	REMARKS	91
14.	ADVERTISING GUIDELINES AND DRAWINGS	93
15.	FINAL CLAUSE	94
15.1.	COMING INTO FORCE	94
15.2.	MODIFICATIONS	94
15.3.	INTERPRETATION.....	94
16.	GLOSSARY	96

1. IBSF COMPETITIONS

The IBSF competitions consist of the following events:

1.1. Olympic Winter Games

- 1.1.1. Olympic Winter Games**
- 1.1.2. Winter Youth Olympic Games**

1.2. Championships

- 1.2.1. World Championships**
- 1.2.2. Junior World Championships**
- 1.2.3. Continental Championships**
 - 1.2.3.1. European Championships**
- 1.2.4. Junior Continental Championships**
 - 1.2.4.1. Junior European Championships**
- 1.2.5. Para World Championships**
- 1.2.6. Summer Push World Championships**

1.3. Official IBSF Competitions

- 1.3.1. World Cup Competitions**
- 1.3.2. Intercontinental Cup Competitions**
- 1.3.3. Asian Cup, Europe Cup and North American Cup Competitions**
- 1.3.4. IBSF Sanctioned Competitions**
- 1.3.5. Para World Cup Competitions**
- 1.3.6. Youth Competitions**
- 1.3.7. Summer Push Competitions**

1.4. Test Competitions and International Training Period

The Organizers of IBSF competitions to be staged on newly constructed tracks shall offer all Members enough training periods for their men's and women's bob teams in advance, during the preceding season, respectively during the same season of the competition within the same season.

Training heats prior to races are to be offered also on any tracks that have been subject to constructional changes.

The Organizers of the Olympic Winter Games to be staged on newly constructed tracks shall offer a number of at least 40 training and competition heats per World-Cup quota prior to the Olympic Winter Games to all Members. These training heats and competition heats must be offered in the form of two or more International Training periods and/or test events,

scheduled throughout the season. Video footage obtained by the IBSF during the homologation will be made available to all National Federations.

Prior to the Olympic Winter Games, the Organizers must also hold at least one test competition.

The quotas for participation in the International Training periods are the same as for the World Cup of the season in which the International Training periods are held.

All remaining Nations, which have no quotas for the participation in the World Cup, have the right to participate in the International Trainings periods with 1 men's bobsleigh team and 1 women's bobsleigh team, provided that their pilots (male pilots and female pilots) have taken part in and been ranked in, a minimum of 5 IBSF competitions on a minimum of 3 different tracks in the course of the previous 24 months. Participation only counts for the respective discipline (e.g. 2-man Bobsleigh counts only for 2-man Bobsleigh).

For these 5 IBSF competitions both the 2-woman Bobsleigh results and the Women's Monobob results of a female pilot will be taken into account. If a female pilot has fulfilled this participation criteria by October 1st of the respective season, it remains valid for the entire current season.

The Organizer must offer at least 40 training heats to those pilots.

The crews that do not have the right to compete in the World Cup, may not participate in the "Test event" but they can train during this time.

Moreover, for reasons of fairness and safety, immediately prior to the start of official training for the Olympic competitions (whether before or after the Opening Ceremony), the men's and women's bobsleigh teams registered for the Olympic Winter Games must be given the possibility of at least 4 additional training heats.

Male and female pilots who in the previous and/or current season placed in the top 15 of the IBSF rankings for discipline and Combined cannot do additional training heats beyond the number prescribed by the present Article. This does not apply to athletes from the host country.

Moreover, the Organizer of the trainings periods and Test Event must grant that all participating athletes and their assistants/coaches will be provided with lodging in at least a three-star hotel, full board, (bed + 3 meals) at a maximum price of € 110,-- per day/**double room**.

The Organizer of the World Championships must offer an International Training period, to prepare for them and it must take place during the same competitive season in which the World Championships are organized. This International Training Period must comprise at least 4 training days with 3 trainings runs per day and has to be approved by the IBSF.

The Organizer is exempt from doing this if during the preceding competitive season a World Cup competition had been organized on the same track.

During the International Training Periods for the Olympic Winter Games and/or World Championships, the Organizer shall offer training heats upon payment of the following amounts: a maximum of € 15 for each Women's Monobob training heat, € 15 for each 2-man

and 2-woman Bobsleigh training heat and a maximum of € 25 for each 4-man Bobsleigh training heat. At least 6 training heats in Women's Monobob, 2-man Bobsleigh, 2-woman Bobsleigh and 6 training heats in 4-man Bobsleigh shall be offered.

If the training period is to be staged as a test competition, the Organizer must offer the heats free of charge.

However, the Organizer may require payment of the entry fee.

1.5. Allocation of Competitions

a) World Championships

The Congress assigns the World Championships to the respective Member Federations a maximum of four years in advance upon written application.

b) Official IBSF Competitions

The remaining official IBSF competitions are assigned yearly by the IBSF Executive Committee, and must be listed on the IBSF International Calendar.

1.6. Gender and number

If the IBSF International Rules do not explicitly indicate the gender, they apply to both men's and women's bobsleigh. Moreover, the term „team“ is equally referred to Women's Monobob.

2. DISCIPLINES

The following disciplines are contested:

2.1. Men's Bobsleigh

2.1.1. 2-man Bobsleigh

2.1.2. 4-man Bobsleigh

2.2. Women's Bobsleigh

2.2.1. 2-woman Bobsleigh

2.2.2. Women's Monobob

2.3. Team Competition

2.3.1. Bobsleigh/Skeleton Mixed Team

2.4. Other Disciplines

2.4.1. Youth Monobob (see IBSF Youth Rules)

2.4.2. Para Bobsleigh (see IBSF Para Bobsleigh Rules)

2.4.3. Summer Push (see IBSF Summer Push Rules)

3. ADMISSION

The right to participate in championships and official IBSF competitions is reserved only for teams registered by IBSF Members.

The athletes must fulfill one of the following conditions:

- a) They must hold citizenship of the country of the Member concerned, and may not have taken part in international IBSF competitions on behalf of another Member, or
- b) They must have their official residence in the country of the Member concerned, and may not have taken part in international IBSF competitions on behalf of another Member, or
- c) They must have changed their citizenship or their official residence, and have been released by their former Member and accepted by their new Member. In this case, the athlete may represent one of the two Members, but not both.

An athlete may represent only one nation during any competition season, which lasts from October 1st to September 30th of the following year.

Applications to change Federations may only be submitted between March 31st and September 30th of each year.

When athletes switch Nations, they keep their Scores/Ranking in the IBSF Ranking List, as well as the number of competitions in which they have participated; however, they do not keep the right to the previous quotas for participation, which remains tied to the nation of origin.

4. RIGHT TO PARTICIPATE IN COMPETITIONS

4.1. Olympic Winter Games

The criteria for the right to participate in the Olympic Winter Games are determined by the IOC. The qualification rules are determined by the IOC in collaboration with the IBSF. The qualification rules are communicated directly by the IOC to all National Olympic Committees.

4.2. World Championships

The World Championships take place annually, with the exception of the Olympic year. Quotas are based on the current IBSF Discipline Ranking List.

The quotas for participation in the World Championships are as follows:

- | | |
|--------|---|
| Men: | Nations with 3 teams in the Top 25: 3 starting places |
| | Nations with 2 teams in the Top 50: 2 starting places |
| | Nations with 1 team in the Top 60: 1 starting place |
| Women: | Nations with 3 teams in the Top 25: 3 starting places |
| | Nations with 2 teams in the Top 35: 2 starting places |
| | Nations with 1 team in the Top 40: 1 starting place |

4.2.1. Requirements for participation in the World Championships:

- a) Only those pilots can take part who have been participating and ranked in a minimum of 5 IBSF races on at least 3 different tracks in the 24 months prior to the competition. If a pilot has fulfilled this qualification criteria by October 1st of the respective season, it remains valid for the entire current season.
- b) In addition, the pilot must have been ranked in at least 3 of these 5 races on a minimum of 2 different tracks during the on-going season. Participation only counts for the respective discipline (e.g. 4-man Bobsleigh race counts only for 4-man Bobsleigh).
- c) The 3 best-placed teams of the Junior World Championship ranking of the respective discipline, which do not belong to a nation with 3 discipline quota places at the World Championships, also qualify for the World Championships. The general quota system for the World Championships must be respected.

4.3. Junior World Championships

The Junior World Championships take place annually. Only athletes from the Junior categories may participate.

There are two categories: One for athletes that have not yet reached the age of 26 (general category) and one for athletes that have not yet reached the age of 23 years (U23 category). The U23 teams will compete in the same race as the general category teams and appear on the same result list but will additionally have their own result list. All National Federations may participate with a maximum of 4 teams and one additional, if the team is under 23 years old. The Juniors, eligible to participate in the Senior World Championships, will be taken from the overall result list regardless of age and competition.

4.3.1. Requirements for participation in the Junior World Championships:

Participation is allowed only for pilots who have taken part in, and been ranked in, a minimum of 2 IBSF competitions on a minimum of 2 different tracks in the course of the previous 12 months. Participation only counts for the respective discipline (e.g. 4-man Bobsleigh counts only for 4-man Bobsleigh).

All nations may participate with a maximum of 4 teams and earn points. If a pilot earns participation in the World Championships, pilot must respect the rule 4.2.1. Participation only counts for the respective discipline (e.g. 2-woman Bobsleigh counts only for 2-woman Bobsleigh).

Juniors are athletes who are under 26 (or 23 for the U23 category) or reach the age of 26 years (or 23 years for U23) in the period of October 1st to March 31st of the current season.

4.4. Continental Championships

The quotas for participation in the Continental Championships are identical to those of the World Cup if the Championships are held within the course of a World Cup competition. Nations of the respective continent that are not qualified to participate in the World Cup have the right to participate with one team. These teams are ranked only in the Continental Championships and shall receive no World Cup points. They will start at the end of the field according to their IBSF ranking by discipline. Teams with no points will be drawn. They are drawn separately at the end of the field of competitors. In the second race heat, they start according to their ranking after the first heat.

In the event that Continental Championships are not held as part of a World Cup race, the number of participants per discipline is limited to 3, with the names of the pilots to be announced to the Jury President on the occasion of the draw for the race. For these races no points will be awarded for the IBSF ranking.

The Junior Continental Championships will be held in the framework of the corresponding Asian Cup, Europe Cup respectively North American Cup of the current season. There will be two categories: One for athletes that have not yet reached the age of 26 (general category) and one for athletes that have not yet reached the age of 23 years (U23 category).

The Junior Continental Champion is taken from the overall results list regardless of age and competition.

4.4.1. Requirements for participation in the Continental Championships:

Participation is allowed only for pilots who have taken part in, and been ranked in, a minimum of 5 IBSF competitions on a minimum of 3 different tracks in the course of the previous 24 months, with the exception of Asian Continental Championships, where participation is allowed only for pilots who have taken part in, and been ranked in, a minimum of 5 IBSF competitions on a minimum of 2 different tracks in the course of the previous 24 months. Participation only counts for the respective discipline (e.g. 4-man Bobsleigh counts only for 4-man Bobsleigh).

In the event that Continental Championships are not held as part of a World Cup race, the number of teams per discipline is limited to 4 and teams receive no IBSF Ranking points.

4.4.2. Requirements for participation in the Junior Continental Championships:

In relation to the Junior Continental Championships Juniors are athletes who are under 26 (general category) or under 23 (U23) for the second category or reach the age of 26 years (or 23 years) in the period of October 1st to March 31st of the current season. To be considered as a Junior Team all athletes participating must fulfill the Junior age criteria. All National Federations may participate with a maximum of 4 teams and one additional if the team is under 23 years old.

4.5. World Cup and Intercontinental Cup

Quotas for the new season are based on the final results of the previous year's Combined IBSF Ranking List. The Combined IBSF Ranking List includes only those pilots who are ranked both in Women's Monobob and 2-woman Bobsleigh respectively in the 2-man and 4-man Bobsleigh.

If a female pilot misses out for one season due to maternity leave, this pilot will keep her quota spot in the respective race series when coming back after one season. This quota place is assigned to the single female pilot's name, cannot be transferred to another pilot and will be in addition to the quota spot/s assigned to the National Federation.

4.5.1. World Cup

The quotas for participation are determined as follows:

Men & Women: All Nations with a maximum of 3 teams per discipline

4.5.2. Intercontinental Cup

The quotas for participation are determined as follows:

- Men: 4 nations with 3 teams
 6 nations with 2 teams
 all remaining nations with 1 team
- Women: Competitions not held

4.5.3. Requirements for participation in the World Cups and Intercontinental Cups:

Participation is allowed only for pilots who have taken part in, and been ranked in, a minimum of 5 IBSF competitions on a minimum of 3 different tracks in the course of the previous 24 months. For pilots who participated in the previous Olympic Winter Games, in the sport of bobsleigh, the qualification is extended to 36 months. Participation only counts for the respective discipline (e.g. 2-woman Bobsleigh counts only for 2-woman Bobsleigh). If a pilot has fulfilled this qualification criteria by October 1st of the respective season, it remains valid for the entire current season.

The general quota system for the World Championships must be respected.

4.6. Asian Cup, Europe Cup and North American Cup

- a) All nations may participate and score points with a maximum of 4 teams. The male pilots placed among the top 12 and female pilots placed among the top 8 of the current IBSF discipline ranking will not be admitted either to the Asian Cup races, Europe Cup races or to the North American Cup races, unless the respective nation uses its entire WC quota.
- b) The 12 best placed male pilots and the 8 best placed female pilots of last year's IBSF discipline ranking, plus the 12 best placed male pilots and the 8 best placed female

pilots of last year's highlight (World Championships, Olympic Winter Games), are not allowed to participate in the Asian Cup, Europe Cup and North American Cup races in the case of simultaneous World Cup races, unless the respective nation uses its entire World Cup quota.

Exception for Juniors: Junior Continental Championships are excluded from this rule.

Race in race, 2-man and 4-man, during Junior Continental Championships: participation in all races is possible and points will be taken into account.

The deadline is the 1st TCM of the respective series.

4.7. IBSF Sanctioned Competitions

The Organizer together with the IBSF will establish the right to participate, but at a minimum there must be 2 nations per discipline. All IBSF rules and regulations apply unless specifically stated elsewhere in these rules. An athlete may count one (1) of these races as participation in other IBSF competitions per season and discipline.

5. EVENT

5.1. General

Only the IBSF, as well as its Members, have the right to organize international competitions. All official international IBSF competitions shall be organized under the supervision of the IBSF. The IBSF shall award the competition to a Member that is able to undertake the organization of the competition, or is able to pass it on to an association (Club) or an Organizing Committee. The Member remains responsible for the orderly execution of the event.

5.2. Costs

The Organizer to whom the organization of the event has been awarded assumes the entire organization and its costs.

5.3. Track

The Organizer shall make the track available in the best possible condition for the official training and the race. The usage of the track during the official training and the race is free of charge.

5.4. Event Announcements and Invitations

The Organizer of the competition shall be responsible for the event announcements and invitations.

The Organizer must present the official event announcement with the program schedule to the IBSF Executive Committee for approval by August 15th.

The Organizer must send the program schedule to the Member Federations and the appointed Jury Members within two weeks of receiving the approval of the IBSF.

The event announcement must include:

- a) The name of the competition
- b) The location and date of the competition
- c) A schedule for the official training and the race
- d) A short description of the track, including a sketch of the track
- e) The entry deadline
- f) The address of the Organizing Committee with exact office times, telephone number, fax number and e-mail address
- g) The name of the Chief of Organization
- h) The name of the Race Director
- i) The names of the Jury Members and the Technical Delegate, if any
- j) Information about facilities, benefits and hotel accommodations
- k) Any conditions of entry
- l) The location and time of the first team captains' meeting

5.5. Organizing Committee and Race Director

An Organizing Committee and a Race Management Office shall be formed in order to guarantee the orderly execution of the event.

The Race Director must possess an IBSF International Jury License. He is responsible for ensuring that the entire event is carried out in accordance with the IBSF International Rules. He shall ensure that skilled and responsible people hold all the important positions in order to assure the smooth progression of the event. Furthermore, he is obliged to ensure that the track is in perfect condition and that the safety of the athletes, coaches and spectators is guaranteed.

5.6. Technical Equipment

- a) voice communication among the start, the finish and the timekeepers
- b) voice communication between the Race Director and the Jury
- c) numerous loudspeakers
- d) at least two calibrated instruments for measuring runner temperature
- e) an electronic timing system
- f) a room for team captains' meetings
- g) sufficient changing rooms and sanitary facilities
- h) a weight scale, calibrated every year
- i) sufficient transport vehicles
- j) a first aid room
- k) medical service
- l) a doping control room
- m) video surveillance on the track
- n) a room suitable for technical inspections of sleds and runners
- o) a suitable room, possibly next to the start, equipped with Internet connection for the Jury

- p) sufficient computers and photocopiers
- q) a score board
- r) optical and acoustic devices to authorize the start
- s) A large television screen should be present at the start area during all World Cup events.

5.7. Liability Insurance

The Organizer is obliged to obtain sufficient public liability insurance.

The insurance must cover the IBSF staff involved in the respective competition. Upon request of the other party in a case of a claim, the Organizer must provide all communication and insurance documents in English.

5.8. Further Obligations of the Organizer

The obligations of the Organizer of IBSF competitions are specified in writing within the framework of a contract that is negotiated between the IBSF and the Organizer's National Federation. The Organizer shall make available all official times recorded during the trainings and the race to the team captains of all participating nations as quickly as possible, preferable by email or in an electronical way. The results should be accessible online. Upon request the official times can be printed. Training and Race results must be uploaded (including a .pdf file) to the IBSF e-license system immediately after the session is finished not later than midnight the same time zone of the Race location and forwarded to the media.

6. JURY AND TECHNICAL DELEGATES

6.1. Jury License

The Jury Members and Technical Delegates, appointed by the IBSF Executive Committee, must possess an IBSF International Jury License in order to officiate. Each National Federation has the right to recommend people suitable for obtaining an IBSF International Jury License.

This License can be acquired after taking an examination on the IBSF International Rules for Bobsleigh and Skeleton. In principle, the examinations take place two times per year, on the occasion of the World Championships and of a World Cup competition on a different continent. The respective National Federations must register potential candidates with the IBSF General Secretary in advance (at least one-month prior).

6.2. License for Material Controls

In order to be allowed to execute their office, the Material Controllers appointed by the Executive Committee must have an International Material Controller License of the IBSF. Each National Federation has the right to propose candidates who are eligible to obtain the International Material Controller License of the IBSF. The examinations will be held as specified by IBSF announcement. The respective National Federations must register potential candidates with the IBSF Secretary General in advance (at least one month prior).

6.3. Nomination

The IBSF Executive Committee nominates the Juries and the Material Controllers. The National Federations have the right to make recommendations.

6.3.1. Olympic Winter Games

- a) one or two Technical Delegates
- b) a Jury President
- c) two Jury Members
- d) two Jury Assistants, if required
- e) two or three Material Controllers

6.3.2. World Championships

- a) one or two Technical Delegates
- b) a Jury President
- c) two Jury Members
- d) two Jury Assistants, if required
- e) two Material Controllers

6.3.3. Junior World Championships, Continental Championships, World Cup and Intercontinental Cup

- a) one or two Technical Delegates
- b) a Jury President
- c) two Jury Members
- d) Jury Assistants, if required
- e) two Material Controllers

6.3.4. Asian Cup, Europe Cup and North American Cup

- a) one or two Technical Delegates
- b) a Jury President
- c) one or two Jury members
- d) one or two Material Controllers

6.3.5. IBSF Sanctioned Competitions

A Jury President or a Technical Delegate who represents the IBSF, with the task of controlling and supervising the event.

6.4. Authority

6.4.1. Jury

The Jury is the highest authority of the competition and implements control with the right to make final judgments within the scope of the IBSF International Rules.

The decision of the Jury is final, incontestable and takes effect immediately.

Furthermore, the Jury is responsible for:

- a) Potential changes of the ice temperature
- b) Any change of sleds
- c) Any change of runners
- d) Any repetition of a heat
- e) Any reduction/increase in the number of training heats
- f) Any interruption or cessation of the race, after consultation with the Race Director and the Chief of Track
- g) Any reduction in the number of participants
- h) Any penalties for rule violations
- i) The length of the start grooves
- j) The number of pilot sleds
- k) The temperature and weight checks
- l) Decisions regarding protests
- m) Any suspension of athletes
- n) Closing the track in case of danger

6.4.2. Technical Delegates

During the Olympic Winter Games one Technical Delegate for Bobsleigh, one Technical Delegate for Skeleton and one additional Technical Delegate are to be appointed. During the World Championships one Technical Delegate for Bobsleigh and one Technical Delegate for Skeleton are to be appointed.

In principle, for all other IBSF events only one Technical Delegate may be appointed for both disciplines.

The power to make decisions regarding the event lies exclusively with the Jury.

If no Technical Delegate has been appointed, the Jury President acts automatically also as Technical Delegate.

6.4.3. Attendance

The Jury President must be available from the first team captains' meeting onward. The Jury is responsible for the compliance with the IBSF International Rules from the start of the official training to the end of the awards ceremony. In cases of absence of a Jury Member, the IBSF appoints a substitute.

6.4.4. Expenses

The IBSF Executive Management Committee determines annually the reimbursement of allowable expenses of the Jury and the Technical Delegate, and informs all concerned by circular letter.

6.4.5. Authority to Inspect

During the training and the race, the Technical Delegate and each Jury Member shall have access without prior notification to all technical equipment and facilities necessary to hold the competition.

6.4.6. Special Decisions

The Jury is also responsible for all decisions pertaining to the competition that are not specified in these Rules.

7. RACE DIRECTOR

7.1. Appointment

The Race Director, appointed by the Organizer, must possess an IBSF International Jury License for all official IBSF competitions.

7.2. Duties

The Race Director is responsible for ensuring that, under the direction of the Jury, all measures are taken that are necessary for the orderly progression of the competition according to the IBSF International Rules. This includes the progression of the team captains' meetings, the training and the race.

Potential necessary changes taken on short notice must first be arranged with the Jury and the IBSF Coordinator.

He shall inform the Jury President immediately about all measures.

In particular, the race director decides upon the use of the sunshades during rain, snowfall or sunshine in consultation with the Technical Delegate, the Coordinator, the Jury and the Track Manager. The use of the sunshades and the sweeping protocol can also be changed during a race or training heat depending on the weather conditions. The final decision will be made by the Jury (for any training, e.g. ITP before and during the Olympic Winter Games and the Winter Youth Olympic Games by the Technical Delegate) in consultation with the Track Manager.

8. GENERAL REGULATIONS

8.1. Sporting Year

The sporting year of the IBSF runs from October 1st to September 30th of the following year.

8.2. Liability

The IBSF assumes no liability for accidents, damages, or other claims that should result from the allocation of the competition or from its proceedings.

8.3. Amateurism Rules

The rules of the IOC are adopted.

8.4. Licenses

All athletes must be registered electronically by their National Federation for an IBSF International License prior to participating in an IBSF supervised event. The minimum age for athletes obtaining an IBSF International License is 15 years of age. However, athletes who will turn 15 years of age during October 1st and March 31st of the current season are eligible to apply for an IBSF International License as well. This applies for men's and women's bobsleigh. However, the minimum age for Youth Monobob events is 13 years of age. Athletes under the age of 18 require the permission of their parents or legal guardian in order to exercise the sport of bobsleigh. The parents or legal guardian must sign the letter of permission and the signature must be officially certified.

The IBSF Electronic License must be filled out in all details and certified by the President or a duly authorized Officer of the National Federation and submitted with a digital photograph.

By registering for a license, the National Federation verifies and confirms that the athlete:

- a) has had a medical check and has met the medical requirements for bobsleigh. The medical check has to be repeated each year, whereas the date of the check shall not be before April 1st to be valid for the upcoming season;
- b) is covered by insurance against accidents deriving from the practice of bobsleigh training or racing;
- c) is covered by insurance against liability;
- d) has been issued the IBSF International Anti-Doping Rules;
- e) has signed a copy of the IBSF Athlete Code of Conduct;
- f) has received at least a basic introduction to Anti-Doping (within the last 3 years) either through an introductory or a refreshment course (in-person or online) offered through the National Anti-Doping Organization (NADO), the National Federation (NF) or by the World Anti-Doping Organization (WADA).

The license is valid for one season (October 1st to September 30th).

8.5. Insurance

The Member Federations of the IBSF are responsible for ensuring that each of their athletes is sufficiently covered by accident and disability insurance, as well as public and third party liability insurance. All risks that may arise from an accident must be completely covered by the insurance.

8.6. Entries

The entry deadline for IBSF events is 4 weeks prior to the 1st Team Captains Meeting and the number of pilots must be specified. Five days prior to the 1st Team Captains Meeting all athletes must be registered.

- a) The name of the team captain, with email address, telephone number and accommodation details, must be provided at the time of the entry.
- b) The entries of the teams for the races must be made online by the Members to the Organizer prior to the deadline specified in the announcement of the event and IBSF detailed race schedule.
- c) The entry fees belong to the Organizer and amount to the value of € 20 per athlete and discipline.
- d) Change of entries:
 - a. Pilots: According to the Rules, Art. 10.5 "Replacement of Athletes" - this is a name change and not a late entry.
 - b. Bobsleigh brakeman: a change of name of a brakeman is possible at any time. This is not a late entry but only a name change. If necessary, medical proof must be provided.
- e) The name of the team members, who will compete in the race, must be communicated by the team captain prior to the draw.
- f) Entries may be withdrawn at any time. Already paid entry fees are non-refundable.
- g) Entry fees must be paid as stated in the announcement of the event.
- h) If the entry of a team is not withdrawn by the first team captains' meeting, the entry fee must be paid in any case.

8.7. Acceptance of the International Rules

With the submission of the entry, the participants (athletes, team captains, coaches and support staff) accept these Rules as binding.

8.8. Track Records and Start Records

Track records and start records will only be recognized by the IBSF if they have been performed during official international IBSF races. The record may be recognized if the team has been subjected to a weight test and their sled to a technical inspection during the competition. If the record is equaled in a subsequent race heat, it does not count as a record. In the event of a draw in the same race heat, more than one team may be listed as the record

holders. The record cannot be recognized until it has been stated that there have been no violations of the IBSF International Rules.

8.9. Doping Controls

Doping is prohibited.

The IBSF Executive Committee can arrange for doping controls at all IBSF competitions and at any time outside of the competitions.

The doping controls are carried out according to the IBSF Anti-Doping Regulations.

The IBSF Executive Committee can authorize international specialized facilities to carry out these controls.

By signing the IBSF International License, the athlete is obliged to accept the IBSF Anti-Doping Regulations and to submit to the controls determined by the IBSF Executive Committee.

By signing the Acknowledgement and Agreement, the athletes, team captains, technicians, coaches and support staff recognize the new IBSF Anti-Doping Regulations.

8.10. Rule Violations

The Jury is responsible for the compliance with the IBSF International Rules and Code of Conduct or the Olympic Charter during an IBSF competition. The Jury determines the sanctions for violations against the provisions of the International Rules and the Code of Conduct, e.g. unsportsmanlike behaviour according to the gravity of the offence:

- a) a warning
- b) a fine
- c) disqualification from the competition
- d) application to the Executive Committee to suspend the pilot as well as the whole team for several races
- e) application for withdrawal of the license to the Executive Committee.

The athlete concerned or his National Federation has the right to defend himself before a final decision is made regarding the cancellation of the International License.

The fine is collected by the Jury, which forwards it to the IBSF.

8.10.1. Athlete Support Person Rule Violations

An Athlete Support Person (Coach, sled or runner builder, physio or any other person) may be deemed to have broken or contributed to the breaking of IBSF International Rules, any Code of Conduct or the Olympic Charter during an IBSF competition, e.g. unsportsmanlike behaviour. In this case the Jury can determine immediately the sanction for the violation according to the gravity of the offence:

- a) a warning
- b) a fine
- c) exclusion from the competition / venue
- d) application for exclusion from future IBSF competitions to the Executive Committee

8.10.2. Prohibited Association

In the event that an Athlete Support Person is disqualified from an IBSF event or events (8.10.1) it is prohibited for an athlete (athletes, team or nation) to associate with this person for the duration of their disqualification. If after receiving a written warning the athlete (athletes, team or nation) continues to associate with the disqualified person the athlete (athletes, team or nation) may be given a:

- e) fine
- f) disqualification from the competition
- g) disqualification from future competitions

In order for this provision to apply, it is necessary that the athlete (athletes, team or nation) has been advised in writing by the IBSF of the Athlete Support Person's disqualifying status and the potential consequence of prohibited association and that the athlete can reasonably avoid the association.

8.10.3. Burden of Proof

The burden shall be on the athlete (athletes, team or nation) to establish that any association with the Athlete Support Personnel described in Article 8.10.1 or 8.10.2 is not in a professional or sport-related capacity.

8.11. Sponsorship and Advertising

The IBSF and its Member Federations can negotiate contracts with commercial firms or organizations.

8.12. Trademarks on Equipment

8.12.1. IBSF Properties

The IBSF property areas for advertising with sponsors or similar entities are governed by the IBSF Advertising Guidelines. The specifications established therein shall be followed. Violations result in penalties.

8.12.2. Freely Available Advertising Areas

With the exception of the areas entitled to the IBSF in accordance with the IBSF Advertising Guidelines, unlimited advertising may be placed on the sled, the equipment and the athlete.

8.13. General Principles

The IBSF recognizes manufacturer's identification on the equipment for bobsleigh and skeleton only for those companies who comply with the definition as set out below.

„Competition Equipment“ implies all items of equipment used by athletes in bobsleigh and skeleton, including clothing, helmets, sleds, runners and other implements that serve a technical function and are manufactured specifically for bobsleigh or skeleton sports. The

entire competition equipment forms a functional unit. In this connection the principle of safety and fairness must be observed.

“Effective Manufacturer” means a natural or legal person which (1) itself designs and/or manufactures¹ the Competition Equipment and/or (2) effectively controls and manages the design and/or manufacturing of the Competition Equipment under its own responsibility through customary subcontracting processes, and whose Competition Equipment is effectively offered on the market to end users.

If requested by the IBSF, the Effective Manufacturer shall provide documentary evidence of such commercial activities at retail level (such as manufacturing activity in the market of the relevant Competition Equipment, including control over the manufacturing process, retail activity and marketing expenditures linking the brand to the relevant piece of Competition Equipment) as a condition for the commercial markings to be accepted as a Manufacturer’s Identification as further defined.

Only manufacturers that have been active over two seasons before the Olympic Winter Games manufacturing Competition Equipment being used in bobsleigh and or skeleton sports qualify as Effective Manufacturers.

“Manufacturer’s Identification” means the name, trademark, brand, logo, or other distinctive sign of the Effective Manufacturer under which the particular Competition Equipment is manufactured and commercially offered to the market (excluding encrypted or encoded supports, such as barcodes or QR codes, as well as URLs, social media accounts and hashtags). The Manufacturer’s Identification must be a sports equipment brand, which means that the Manufacturer’s Identification is principally used for Competition Equipment and is (i) not principally used for non-sports equipment, and/or (ii) cannot be confused with a similar or identical article used in another line of business, unrelated to Competition Equipment. Should the manufacturer be an individual, the name and surname of such manufacturer is considered Manufacturer’s Identification unless provided otherwise.

9. MEDICAL SERVICE AT THE TRACK

9.1. Race Medical

The following must be available at the track during the official training heats and the race heats:

- a) One medical specialist with certified knowledge/training of emergency medical aid
- b) One medical vehicle used as emergency ambulance
- c) One room exclusively used for first aid treatment – which is marked as such.

¹ Design and/or manufacture, as referred to in the above definition, may include specification development, production, fabrication, assembly, processing, of a Competition Equipment; or putting a collection of devices, and possibly other products, together for bobsleigh or skeleton sports.

Recommended for race days in addition:

One medical doctor with knowledge of sports and able to decide "Fit to slide" – e.g. concussion...

One medical vehicle must be present at all times on the track. In case the medical vehicle is leaving the track, training/race must be stopped.

Should medical personnel be medically required, training/race must be stopped.

The Organizer shall be attentive to this regulation, as the Organizer is responsible for compliance with these requirements.

The IBSF Medical Committee decides on any possible exceptions to the above. The Jury President must be informed of these exceptions prior to the start of the official training.

Tasks of the race medical:

- a) responsible for the first medical aid for injuries and illnesses of the athlete
- b) coordination of transportation of injured or ill athletes for further medical treatment
- c) after every crash, the athlete must come to the race medical for an examination in order to obtain the authorization to participate further in the training or in the race. If the race medical suspects a concussion or serious injury, athlete's license must be invalidated ("mark the box on the form"), he is entitled to prohibit the concerned athlete from further participation. In these cases, the race medical must immediately inform the Jury President of the athlete's inability to continue to participate in the competition, and the athlete is accordingly officially removed from the competition. The Jury President immediately will inform the respective IBSF coordinator to temporarily unlicense the concerned athlete. The race medical must complete an Injury Registration Document after every examination of an injured athlete. All of these documents must be forwarded to injury@ibsf.org on a daily basis.

Only a medical doctor can provide "Fit to slide" approval to return to sliding.

9.2. Team Medical/Doctor

Race medical/doctor and team medicals/doctors should cooperate on evaluation and treatment.

9.3. Evacuation of injured athletes

The event Organizers must guarantee that injured athletes can be transported away from any point of the entire length of the track.

10. THE COMPETITION

The competition starts with the 1st Team Captain Meeting and ends after the award ceremony subject to any material control or doping control results and/or any unclosed possible protests of the race concerned. During a competition (the official training and the race), pilots are not permitted to make heats on the track outside of the official schedule, nor are they permitted to conduct training or races on other tracks at the same time or compete on more than one circuit. Replacement pilots who start participating in the official training at a later stage, may have made training heats on other tracks. However, teams are allowed to conduct training or races on other tracks in the first week of a two-week competition.

During the Olympic Winter Games and World Championships those pilots who are qualified for 4-man Bobsleigh only, are not allowed to make any 2-man, 2-woman or 4-man competition or training heats during the 2-man Bobsleigh race competition week on that track, with the only exception of two 2-man Bobsleigh training heats for the Team Event during the World Championships on that track.

The same procedure is valid for 2-woman Bobsleigh and Women's Monobob.

In principle, the period right after the race and the day after the race the athlete participated in, is considered as travel day. On IBSF Travel Days no athlete may participate in a training or race on another track if an IBSF event is listed in the calendar for that week.

10.1. Official Training

- a) Participation in the official training is only permitted for registered athletes for the race.
- b) Only the name of the pilot and discipline for each training day is to be entered for the training. The National Federation is responsible for granting the respect of Art. 10.1. subpar. c).
- c) Only athletes belonging to the same nation holding a valid IBSF license and registered for the competition may participate in one team for training.
- d) In case of violation of Art. 10.1 the team can be admitted to the race in exceptional cases, and the team captain will be punished by the jury.
- e) At all official IBSF competitions, each pilot must complete two training heats per discipline without accident to be allowed to participate in the race, except pilot competes in the World Cup/Asian Cup/Europe Cup/North American Cup in both disciplines. In that case one valid training heat per discipline is sufficient. If training and racing for one discipline is completed prior to training for the second discipline, two training runs must be completed for the first discipline.
- f) If the training is conducted from various start heights, the required minimum break between the use of one start height and the use of another is 5 minutes.

10.1.1. Olympic Winter Games and World Championships

Directly prior to the race, 6 official training heats in each of Women's Monobob, 2-man Bobsleigh, 2-woman Bobsleigh and 4-man Bobsleigh shall be offered.

10.1.2. Continental Championships, World Cup and Intercontinental Cup

- a) Directly prior to the race, official training days with a total of 6 official training heats (2-woman Bobsleigh and Women's Monobob, 2-man Bobsleigh and 4-man Bobsleigh combined) shall be offered.
- b) Each pilot may freely choose the program by which pilot makes his training heats. However, each pilot may only take a maximum of 4 training heats in any discipline.
- c) For men and women, a minimum of two valid training heats per discipline without accident must be completed in order to be allowed to participate in the race, with the exception of rule point 10.1. subitem "e".
- d) Two valid training heats per discipline without accident are sufficient even in a double race, with the exception of rule point 10.1. subitem "e".
- e) Exception for the World Cup according to article 10.1.5

A Nation may sign up different pilots for the 2-woman Bobsleigh, Women's Monobob, 2-man and 4-man Bobsleigh competitions. In this case the nation will be assigned up to a maximum of 4 heats per pilot/discipline for each pilot in addition to the quota. Only one additional pilot per training day is admitted.

In the case the number of training heats/days is reduced, a pilot who participates in one discipline only may make the same maximum number of heats per discipline as a pilot who participates in combined disciplines.

The pilots who participate in **both disciplines in the respective race** and have not made any training and race heats previously on the respective track, may make two additional training heats during the World Cup events up to a maximum of four heats per discipline. These heats are to be announced during the first team captains' meeting and will be granted by the Jury after consultation with the team captain and the Race Organizer. No additional training day will be offered. The additional heats must be completed during the normally scheduled training days.

10.1.3. Junior World Championships, Asian Cup, Europe Cup and North American Cup

These competitions can be done according to the World Cup program: training heats can be done during the week whereas competition heats will be held on the weekend. The pilots can choose on which training day they want to do which discipline.

Pilots just performing in one discipline have a right – if possible – of 2 training heats each on all training days. The pilots can choose to train either Women’s Monobob, 2-man Bobsleigh, 2-woman Bobsleigh or 4-man Bobsleigh during the first training session.

To be admitted to the race teams need to have at least two training heats without any accident and according to the IBSF rules.

If there are double-races training and competition heats can be separated as before. That means there will be training heats in 2-man Bobsleigh and 2-woman Bobsleigh first, than 2-man Bobsleigh and 2-woman Bobsleigh competition, followed by 4-man Bobsleigh training heats and 4-man Bobsleigh competition.

10.1.4. IBSF Sanctioned Competitions

The Organizer together with the IBSF will determine the number of official training heats. A minimum of 3 official training heats must be offered.

10.1.5. Changes to Official Training

The IBSF can modify the number of official training days and/or training heats in official IBSF competitions.

10.2. Starting Order during Training

The starting order of the participating nations will be drawn by the technical delegate/coordinator after the registration deadline (five days prior to the 1st Team Captains Meeting). If possible, the training is run according to “nation groups”.

10.2.1. Olympic Winter Games:

The starting order of the participating nations will be drawn at the first team captains meeting.

10.2.2. World Championships:

The starting order of the participating nations shall be drawn by the Technical Delegate at the end of the registration deadline (five days prior to the 1st Team Captains Meeting) and after the quota allocation and shall be communicated to both the Race Organizer and the participating nations prior to the first team captains’ meeting. Nevertheless, the team captains have to be present at the first team captain meeting. If a nation is not present the athletes of the nation concerned shall automatically start at the end of the field during the first and second day.

10.2.3. All other official IBSF races according to rule point 1.3:

The starting order of the participating nations shall be drawn by the coordinator at the end of the registration deadline (five days prior to the 1st Team Captains Meeting) and shall be communicated to both the Race Organizer and the participating nations prior to the first team captains’ meeting. Nevertheless, the team captains have to be present at the first team captain meeting. If a nation is not present the athletes of the nation

concerned shall automatically start at the end of the field during the first and second day.

The following starting order applies for events in which the official training takes place for 2 or 3 days:

1st day: From nation 1 to the end

2nd day: From the end to nation 1

3rd day: By individual according to the 2-woman/2-man bob IBSF ranking (based on best-placed pilots presenting/starting, women and men separately). During the World Championships and the Olympic Winter Games the starting order for Women's Monobob, 2-man Bobsleigh, 2-woman Bobsleigh and 4-man Bobsleigh will be defined on the basis of the IBSF ranking of each of these four disciplines.

10.3. Track Conditions during Training

If possible, the final day of official training should take place at the same time as the race and the track preparation should correspond to the conditions of the race. No alterations to the track profile should be made after the final training session.

10.4. Start Grooves

The start grooves are determined by the Jury on the first day of training and can only be modified upon their command. Both grooves shall be prepared appropriately for skeleton runners (minimum of 17 mm wide). The sleds must start in both start grooves for the start procedure.

10.5. Replacement of Athletes

It is possible to replace an athlete with another athlete from the same National Federation at any time during training. However, a pilot may only be replaced if the replacement pilot is still able to achieve the minimum number of accident-free training heats without any change to the schedule. The pilot who has been replaced cannot be re-entered again to the same competition.

A pilot who carries out heats beyond the official training (for example, as a pilot sled or in the "guests" class) cannot take part in the competition later on. The jury can make an "exception" to allow such pilot's participation in the "Team Competition".

Double Competition:

During double competitions on the same track, the National Federations can sign up different pilots for the second competition from those participating in the first competition.

The new pilots will be given the same number of training heats as the other teams. This applies only for World Cup and North American Cup, whereas in Europe Cup only one new pilot may use the same number of training heats. All pilots have to be already registered for the 2 races at the first Team Captain's Meeting (TCM).

The replacement athlete must hold a valid IBSF International License.

10.6. The Race

10.6.1. Race Heats

An IBSF race can be held over 2 or 4 heats. A reduction in the number of heats is possible in cases of force majeure. At least one race heat must be conducted for the race to be officially valid.

a) 4-Heat Races

In principle, the Olympic Winter Games and the World Championships are held over 4 race heats.

b) 2-Heat Races

The Continental Championships, the Junior World Championships and all other official IBSF races are held over 2 heats.

10.6.2. Starting Order

Starting order for 2-Heat races:

1st race heat: From 1 to the end

2nd race heat: From 20 to 1, according to the ranking of the first race heat

Starting order for 4-Heat races:

1st race heat: From 1 to the end

2nd race heat: From 25 to 1 and from 26 to the end; according to the ranking of the first race heat or if less than 26 participants, end to 1.

3rd race heat: From 1 to the end, according to the ranking after two race heats

4th race heat: From 20 to 1, according to the ranking after three race heats

10.6.3. Starting Order System

For a race to be awarded with IBSF points, a minimum of 6 teams from a minimum of 2 nations must be drawn for the race. However, in case only 5 or fewer teams are drawn for the race, no IBSF points will be awarded. Nevertheless, the race will count towards fulfilling the requirements according to rule points 4.2.1, 4.4.1 as well as 4.5.3.

Olympic Winter Games and Junior World Championships

In order of their IBSF Discipline Ranking position, the 10 best-placed pilots in the current IBSF Discipline Ranking List who are present will choose their start numbers 1 to 10 for Men's Bobsleigh and Women's Bobsleigh. All other pilots start according to the order in the current IBSF Discipline Ranking List from start number 11 (Men's Bobsleigh and Women's Bobsleigh) to the end.

Where allowed in these Rules to choose their start numbers the best placed pilot who is present will choose first, the second best pilot will choose second and so on.

World Championships

In order of their position in the World Cup Discipline Ranking, the 10 best-placed pilots in the current World Cup Discipline Ranking List who are present or represented will choose their start numbers 1 to 10 for Men's Bobsleigh and Women's Bobsleigh. All other pilots start according to the order in the current World Cup Discipline Ranking List from start number 11 (Men's Bobsleigh and Women's Bobsleigh) to the end.

Pilots without World Cup Discipline Ranking Points will be drawn at the end of the field.

Where allowed in the International Rules Bobsleigh to choose their start numbers, the best placed pilot who is present will choose first, the second best present pilot will choose second and so on.

Continental Championships, World Cup, Intercontinental Cup, Asian Cup, Europe Cup and North American Cup

The season starts on the basis of the IBSF Discipline Ranking List from the previous season. The 10 best-placed pilots in the current IBSF Discipline Ranking List who are present are drawn for the assignment of start numbers 4 to 13 for Men's Bobsleigh and for Women's Bobsleigh. For Men's and Women's Bobsleigh the first three pilots will be drawn from the last ten ranked pilots. All other pilots start according to the ranking in the IBSF Discipline Ranking List from start number 14 (Men's Bobsleigh and Women's Bobsleigh) to the end.

For any following race, the corresponding race series Ranking List will be used to determine the starting order.

The 10 best-placed pilots in the Discipline Ranking List of the corresponding race series who are present are drawn for the assignment of start numbers 4 to 13 for Men's Bobsleigh and for Women's Bobsleigh. For Men's and Women's Bobsleigh the first three pilots will be drawn from the last ten ranked pilots. All other pilots start according to the ranking in the current Discipline Ranking List of the corresponding race series from start number 14 (Men's Bobsleigh and Women's Bobsleigh) to the end.

If only 10 or less pilots are registered for a race, all pilots will be drawn.

If 11 to 13 pilots are registered for the race, the 10 best placed pilots in the current Discipline Ranking List of the corresponding race series, who are present, will be drawn for the assignment of start numbers 4 to 13 or 3 to 12 or 2 to 11.

The start numbers 1 to 3/2/ are assigned to the remaining pilots by draw.

Pilots without points are drawn at the end of the field.

The Jury holds the draw in public. An electronic draw by computer is possible. The pilots keep their start numbers for the duration of the competition.

At public draws the pilots must be present at the behest of the Jury. If the pilot is not present, he/she will be subject to a sanction to be determined by the Jury.

10.6.4. Start Number

The Organizer supplies the teams with the start numbers. The size of the number should be approximately 40 cm².

The start numbers must be affixed according to the instructions of the Jury on the left side next to the pilot's push bar. They cannot be modified.

10.6.5. Teams and Manner of Driving

All race heats must be run with the same team.

In cases of injury or illness and with the permission of the Jury, an athlete may be replaced with an athlete from the same National Federation, with the exception of the pilot. The request for replacement shall be made in writing by the team captain. A medical certificate from the team doctor or the race doctor shall be enclosed or shall be given subsequently as soon as possible, as the case may be.

The Race Doctor or race medical and the Jury are authorized to prohibit athletes in inadequate mental or physical condition from competing. Only driving from the sitting position is allowed.

After a crash, the entire team must cross the finish line together with the sled in order to be ranked. If the sled should come to a stop before the finish line, the team is disqualified. The help from third party is not permitted.

10.6.6. Track Conditions during the Race

The track is prepared after agreement among the Jury, the Race Director and the Chief of Track.

In case of snowfall, it shall be made certain that a regularly scheduled race is possible. Particular attention shall be paid to the ice surface at the start up to the start time measurement (50 m), which shall be swept prior to the start of each sled. In particular, the start grooves are to be swept. The track must be swept regularly. The race director must prepare a written protocol for sweeping in consultation with the Jury. The written protocol has to be announced no later than the final Team Captains Meeting.

10.6.7. Track Walks

The times for the track walks are determined after agreement between the Race Director and the Jury, and are disclosed at the first team captains' meeting. Track walks are not allowed outside of these times. Entering the track during a heat is absolutely prohibited.

There are no track walks on race days.

On training days, the athletes are free to choose the start of the track walk from start or finish.

10.6.8. Start

The start block may be stepped upon during the start procedure, but the rear edge may not be crossed.

The start line (the first timing point) must be clearly visible.

The entire team shall be present after the call to the start.

The starter clears the track by means of acoustic and optical signals. The team at the start must activate the timing device within 60 seconds.

The athletes can accelerate the sled by pushing it.

The help from the third party during the start procedure is prohibited.

An exception to this is the Women's Monobob, where in case of need - in training - help from third parties can be used for the start procedure between the start block and the initial triggering of the timing.

10.6.9. Reduction

If the number of registered teams exceeds the capacity of the track, the Jury, in agreement with the Technical Delegate and with the Race Director, can reduce the number of participants.

All registered teams must be allowed to compete in the first heat.

The number of teams can be reduced before each subsequent race heat.

The starting order does not change in such a case.

10.6.10. Interruption or Cessation

The Jury, in consultation with the Technical Delegate, the Race Director and the Chief of Track, can interrupt or stop the race for the following reasons, among others:

Damage to the track

Weather conditions

Failure of the timing system or other technical equipment

After an interruption, the team at the start shall be granted a suitable amount of preparation time.

10.6.11. Repetition of a Heat

After a malfunction not caused by the team, the heat may be repeated with the authorization of the Jury. The heat may be repeated as soon as the team is ready to start.

10.6.12. Replacement Races

If a race is cancelled, the IBSF Executive Committee can decide to hold a replacement race at a later date on the same or a different track.

The following teams may participate in the replacement race:

All teams eligible to participate, if the race concerned was cancelled prior to issuing the start numbers, or

Only those teams which have received a start number for the cancelled race. Another drawing of the start numbers is carried out.

10.6.13. Pilot Sleds

The Jury determines the number of pilot sleds. The Organizer is obliged to provide a minimum of three pilot sleds. Only for the World Championships and Olympic Winter Games five pilot sleds are required. Before 2-man Bobsleigh and 2-woman Bobsleigh races, only 2-man Bobsleighs or 2-woman Bobsleighs should be used. Before 4-man Bobsleigh races, only 4-man Bobsleighs should be used.

If the Jury decides there are an insufficient number of pilot sleds available, the Jury can appoint teams that are last in the starting order. These teams start immediately after the pilot sleds, and their pilot heat is also scored as a race heat.

The race Organizer is fully responsible for the selection and composition of each pilot sled.

10.6.14. Timing Equipment specifications

- a) Two independent timing systems, each consisting of at least one time measuring device, complete set of light beams and independent power supply, must be available and in operation during a competition (A and B systems).
- b) The A system comprises all light beams for start, start time, four intermediate times, four speeds and finish time. The first interval time corresponds to the start time (50 m). Four interval times must be evenly distributed among the remainder of the track. For TV and Security reasons minimum 3 more light beams have to be set between Intermediate times and Speed traps in longer unmonitored parts of the track.
- c) The B system comprises at least the start and finish light beams to record the heat time. If a track is assigned to held Olympic Winter Games the B system has to be a 100% backup of the A system.
- d) The time of day of both timing systems (A and B systems) must be synchronized and must provide accurate timing of 1/100 of a second.
- e) All times have to be measured as Day Times. Intermediate times and Finish times are calculated by subtraction of Start time from Intermediate time or Start time from Finish time respectively. The result has to be truncated to 1/100 of a second.
- f) Two evaluation and control computers for the timing system must be available and in operation during a competition.
- g) The times measured by both timing systems must be recorded in both evaluation and control computers of the timing system.
- h) In case of failure of the A system it must be possible to switch to the B system without time delay. After this, the times measured by the B system will be used for the continuation of the competition. The times recorded by the A system up to this point will remain valid.
- i) In case of failure of the evaluation and control computer currently operating, it must be possible to switch to the second computer for controlling the timing system within a short time frame.

The ranking valid up to this point is to be saved.

- j) A check list has to be prepared by the Track operators detailing the switching between the two timing systems and the two control computers.
- k) Independently from the computer, the light beam times recorded by each timing system must be printed as daytimes on a corresponding timeline printer.
- l) For external service providers an online data interface must be available through which they can obtain the measured light beam times (e. g. when TV graphics are required)
- m) Uninterrupted power supply must be available for the timing system (time measuring devices and control computers) securing that at least the time of the current sled to the finish is recorded. The power supply of the light beams of the A and B systems must be independent from each other.
- n) Technical Requirements for Reaction Start (in force with the start of the 2025/26 season)
 - a. General Requirements:
 - i. Power supply: 110 - 240V, 16A, 50/60Hz directly at the starting position on both sides of the track
 - ii. Cable crossing at the start section from one side of the track to the other (if the cable cannot be laid under the track, appropriate cable covers must be provided to run the cable around the start area)
 - b. Cabling:
Combination of Fiber and Copper wire connection
 - c. Main system only:
 - i. 2 Fibers within a fiber glass connection (if possible single mode) from the Timing Room to the Start Position for data connection
 - ii. 1 Pair copper wires twisted pair for Start Impulse
 - iii. 2 Pairs copper wires twisted pair from the Timing Room to the Start Position for data connection

Please note that a backup system requires double the cabling mentioned in all points above and should be provided by the tracks.

10.6.15. Time Measurement

The Organizers have to hand over Time measurements and speeds of all participants to the IBSF Coordinator daily during and at the end of the competition.

Times equal to 1/100th of a second are given the same rank.

If two or more teams achieve the same time in the first, second or third heats, the starting order for these teams in the second, third and fourth heats respectively shall be determined according to the Bib number. In such a case, the team with the highest Bib number is the first to start.

If the number of participants is reduced prior to the final race heat, the eliminated teams remain in the results with their final ranking. If in the final heat a team does not start or

is disqualified, they do not receive a final ranking. The remaining teams move up in the ranking list.

10.6.16. Maintenance of the timing equipment (in place from 2017/18 season on)

- a) For each season the timing equipment must be maintained by a professional company.
- b) A maintenance report will be issued specifying the operations carried out during the maintenance.
- c) Records must be kept of all existing deficiencies which cannot be corrected immediately through the regular maintenance activities (e. g. computer damage).
- d) In the maintenance report it must be confirmed that the timing equipment is ready for use.
- e) The track operator must submit the maintenance report to the IBSF Office prior to the first international competition.

10.6.17. Use of push start facility

Iced or non-iced push start facilities – regardless of whether they are located inside or outside the venue – may not be used during the race days of World Championships, Junior World Championships, Olympic Winter Games or Winter Youth Olympic Games by any athletes who participate in that event. On non-race days during the above Championship and Olympic events the push start facilities can only be used with the approval of the IBSF.

10.7. Parc Fermé

A Parc Fermé should be implemented and adapted to the specific conditions of the respective track.

10.8. Material and Equipment

10.8.1. Sled

In principle, all race heats must be contested with the same sled. If the sled has been damaged beyond immediate repair, a replacement sled may be allowed with the authorization of the Jury.

At all official IBSF Women's Monobob races listed in the IBSF calendar (Olympic Winter Games, World Championships, World Cups, European Cups, North American Cups, International races, Women's Monobob World Series) only the IBSF standardized Monobob provided by iXent will be allowed.

The approval is based on the original measurements and the original drawings of the manufacturer.

With the exceptions listed below, all spare parts will be produced by the sled manufacturer iXent and will be available for purchase. Each of them must carry the manufacturer's identification mark. For example, springs in the division may only be replaced or exchanged by any springs offered by the manufacturer; the front axle leaf spring may only be replaced or exchanged by the offered front axle leaf spring of the manufacturer.

Exceptions:

All repair, modification and/or maintenance work specified in Appendix 1 to these Rules is permitted using original spare parts provided by iXent.

10.8.2. Runners

In all official IBSF races listed on the IBSF-Calendar (Olympic Winter Games, World Championships, Junior World Championships, Continental Championships, WC, ICC, AC, EC, NAC, etc.) only IBSF standard runners (standard material) are admitted. For the Women's Monobob the same runner specifications apply as for the 2-woman Bobsleigh discipline. The authenticity of the runner steel may be controlled by the IBSF Jury and/or IBSF Material Controller at any time. To define the authenticity of the runner steel, inspections may include the analysis of the composition of the runner material and examination of the hardness of the runner steel. Only geometrical changes to standard IBSF runners through the removal of the original material are allowed. No materials may be added in any way.

The use of any means of propulsion is prohibited.

Changing runners between race heats held on the same day is only permitted after damage and with the authorization of the Jury.

At the Jury's discretion, runners can be subjected at any moment to inspection with special equipment. In case of inconclusive findings, runners may be seized and sent to a specialized laboratory for further testing.

10.9. Technical Inspections

The runners must be mounted on the sled when setting up the bobsleighs for training and race. All sleds must be in the start area for the technical inspection at least 15 minutes before the start of the training of the teams.

The sleds participating in the race must be positioned in the start area with mounted runners, in the spaces assigned to them.

All preparatory work performed on the sleds, must be completed 45 minutes before the start of the race.

The sleds must be turned upside down and uncovered so that the runners face upwards.

After this time point, no work may be performed on either the sleds or the runners. Changing runners and replacing sled parts is also prohibited.

The runners may be polished between the race heats. Only the athletes belonging to the team from the sled concerned may perform the work.

After the last sled has been brought back to the start, there must be a break of a minimum of 5 minutes before the next race heat begins.

The runners can only be polished using abrasives provided by the IBSF.

The runners must remain mounted on the sled. The use of any other materials and / or products is prohibited. Violation of this rule is penalized with immediate disqualification from the race.

The Jury can at any time confiscate the abrasives provided by the IBSF, regardless of whether they have been used or not.

Only the Jury, in agreement with the IBSF Material Controller, can give authorization for repair work to be performed on sleds with technical problems.

Between the individual race heats, no further work may be performed with the exception of ballast weight adjustment as described in rule point 10.14 "Weight". This must be authorized by the Jury.

If a set of runners is so damaged during a race that immediate repair is not possible, the team has the possibility to use a new set of runners, after receiving the authorization of the Jury. The new set of runners is subject to the provisions of the IBSF International Rules.

All sleds and runners participating in the race can be subjected to technical inspections. The Jury decides which sleds and runners are to be inspected and when the inspection is to take place. Inspections of the other equipment can also be conducted. The Jury can assign the members of the IBSF Material Controller to carry out these inspections.

In cases of suspicion, components of the sled can be confiscated and subjected to technical inspections. The inspections can be conducted at a mobile laboratory on the competition site. In this case, the Jury evaluates the laboratory results immediately and takes the appropriate action.

If the technical inspections are conducted after the race at a laboratory outside of the competition site, the inspection results are forwarded to the IBSF Executive Management Committee. The laboratory in question must be approved by the IBSF. The procedures used must be in accordance with article 13 of these Rules.

In case the results show proof of a violation against the IBSF International Rules, the IBSF Executive Committee takes the appropriate action. In this case, the National Federation concerned shall bear the costs of the inspection and appraisal. The decisions of the Executive Committee are incontestable.

If it is determined that the IBSF International Rules have been violated, then it automatically results in disqualification from the competition concerned.

10.10. Runner Radius

The Jury or the IBSF Material Controller checks the radius of the runners with an official IBSF gauge.

10.11. Measurement of Runner Temperatures

The runner temperatures are checked before the start according to the instructions of the Jury. All four runners are checked with an electronic measuring device equipped with a temperature measuring sensor and a display device for temperatures between at least +30° C and -20° C.

The Organizer must provide two electronic measuring devices, one for the Jury and one for the teams participating in the race.

The temperature of the runners is measured on the side of the runner in the area of the middle supporting bracket. The measuring sensor shall remain in contact with the runner until the display on the temperature measuring device is stable.

The runner temperature may be checked in the Parc Fermé before the beginning of the 1st, 2nd, 3rd and 4th heat.

The check in the Parc Fermé is carried out from start number 1 to the end upon instructions of the Jury before the beginning of the race.

If a team's runner temperature exceeds the limit, the second measurement of the temperature will be conducted immediately before the "ice bed". Should the second measurement also indicate a temperature that exceeds the limit, it leads to disqualification. This is then to be registered in the Temperature Measurement Protocol.

The runner temperature measurement before the 2nd heat may be waived upon instructions of the Jury.

The temperature of the runners that are mounted on the sled being used in the race may exceed the temperature of the reference runner by a maximum of 4° C. If the temperature of the reference runner is less than -14° C, the runners on the sled may have a maximum temperature of -10° C. If a team's runner temperature exceeds the limit, another measurement of the temperature of the reference runner and of the runner on the sled shall be made immediately following the first measurement. If the second measurement also shows a temperature that exceeds the limit, it leads to immediate disqualification. This is then registered in the Temperature Measurement Protocol.

The temperature listed on the official display will not be updated. The update will be done every 15 minutes (Art. 10.12).

The sled must be moved from its assigned place in the start area to the runner temperature measurement station by carrying it or by pushing it on its side on the bumpers. Cooling down the runners by touching them with snow or ice is not allowed.

10.12. Reference Runner

The temperature of the reference runner is measured according to the following procedure.

- a) The reference runner must be made of IBSF standard runner material. It must be hung or otherwise positioned in the open air 45 minutes before the start of the race, in the same climactic weather conditions as the sleds included in the race. When the reference runner is positioned in the open air, it must show a temperature of between +18° C and +22° C.
- b) The exact temperature of the reference runner at the time it was positioned in the open air must be written on a clearly visible board in the start area. The board must also show the air and ice temperatures.
- c) The temperature of the reference runner is measured on the side of the runner in the area of the middle supporting bracket.
- d) The temperatures shown on the temperature display board are updated as follows:
 - a. The first time, 45 minutes before the start of the race and third heat
 - b. 10 minutes before the start of the race and before the start of the second and fourth heat
 - c. Afterwards, every 15 minutes (This can be omitted for measurements in the parc fermé as soon as all runners were measured within the correct temperature window.)
 - d. In the case of extraordinary climatic conditions (high temperatures), after measuring the runner temperatures the Jury can instruct the teams to place their sleds on the snow or ice immediately before the start.

10.13. Runner Cleaning

The runners are treated and cleaned before the start of the race heats with special cleaning solutions provided by the IBSF.

In every race in which the IBSF standard material is required, all runners may be sanded with sandpaper in the same manner. The sandpaper grade is determined by the IBSF before the start of the season; upon request of the Jury sandpaper with a bigger grain size may be used.

10.14. Weight

The weight is checked using a scale.

Weights can be checked at any time upon decision of the Jury.

The sled and the crew shall be weighed immediately after the conclusion of the race heat, upon request of the Jury. No modifications to the sled or the other equipment may be made. The team shall be inside the sled during the weighing procedure. The first weight test is then made. Each team may request a second weight test, if necessary. For the second test, they have a maximum of 5 minutes to remove snow and ice from the sled. This occurs under the supervision of the Jury.

The observed weight must be registered in the Weight Protocol.

Assistance by a third party is not allowed.

If an athlete needs to be replaced prior to and in between race heats the team may modify the ballast weight.

Minimum Weight:

Sled including the runners and without the crew:

2-man Bobsleigh:	170 Kg
4-man Bobsleigh:	210 Kg
Women's Monobob	163 Kg
2-woman Bobsleigh:	170 Kg

Maximum Weight:

Sled including the crew, the runners and the other equipment:

2-man Bobsleigh:	390,5 Kg
4-man Bobsleigh:	631 Kg
Women's Monobob	248,5 Kg
2-woman Bobsleigh:	330,5 Kg

Women's Monobob: Only the additional weights provided by iXent are permitted as ballast weight.

10.15. Electronic Measuring Devices and Equipment

In the time during which the track is subject to the control of the IBSF (e.g. official training, races, ITP and homologation), electronic or electrical measuring devices or equipment may not be used on the sled, on the athletes or on and beside the track. The IBSF or the Jury concerned has the power to grant exceptions such as specific measurements and/or POV recording (complete bobsleigh heat), especially during a homologation of a track. In these cases the results of the measurements must be made known to all the participating National Federations. Footage obtained during homologation must be made available to all National Federations.

On and beside the track all coaching devices such as radios, ice thermometers and video recording devices are allowed, but this refers exclusively to such video recording devices, which are not controlled remotely and/or stationary and aren't positioned closely or attached to the track. Each National Federation is responsible to use these devices in a secure and safe manner.

TV cameras belonging to the track or IBSF Stakeholders are not subject to this article.

10.16. Other Equipment

10.16.1. Helmet

During training heats and race heats, all athletes must wear a full-face helmet that conforms to ECE, OKM or DOT safety standards, and is commercially available in specialty shops. No aerodynamic elements may be additional attached to the helmet. It is the duty and the responsibility of the National Federations to comply with the safety standards.

10.16.2. Shoes

The use of spikes on the shoes of the athletes is allowed for pushing the sled, as long as the spikes are arranged in brush form.

The maximum diameter of the spikes may not be greater than 1.5 mm, the spikes may not be longer than 5 mm and the minimum amount of spikes per shoe must not be less than 250.

10.16.3. Clothing

Training and race suits with short pants and short sleeves are not allowed.

No aerodynamic elements whatsoever may be attached either outside or under the race suit.

Race suits must be manufactured from an uncoated textile.

For safety reasons, long hair and braids should be covered inside the hood or race suit and should not be worn uncovered over the shoulder or upper back.

10.16.4. Protection vest

All athletes, except the pilot, must wear a protection vest during training and competition. It is the duty and the responsibility of each National Federation to comply with the safety standards and ensure the wearing of the vests are complied with. Failure to comply with this rule will result in a penalty for the National Federation respectively the athlete.

10.17. Awards

10.17.1. IBSF Championships

At official IBSF Championships, with the exception of Junior Continental Championships, the IBSF awards gold, silver and bronze medals to the athletes of the first, second and third placed teams. The athletes of the fourth, fifth and sixth placed teams receive commemorative medals. The Organizer awards additional honorary prizes to the teams. At Junior Continental Championships IBSF awards only gold, silver and bronze medals.

10.17.2. Official IBSF Competitions

The Organizer awards honorary prizes to the athletes of the first to sixth placed teams with the exception of Junior Continental Championships. At the Junior Continental Championships, the Organizer awards prizes to the first to third placed athletes.

10.18. Awards Ceremony

The awards ceremony should take place as soon as possible after the deadline for submitting protests.

The doping controls and technical inspections may also take place after the awards ceremony. At all IBSF Championships and official IBSF competitions, the national flags of the first three placed teams must be hoisted. The national anthem of the winning team must also be played.

10.19. Protests

Protests must be made verbally to the Jury immediately or at the utmost 5 minutes after the heat in which that incident happened. Additionally, the grounds for the protest must be submitted in writing to the Jury no more than 20 minutes after the conclusion of the race.

If no verbal declaration of protest is made, no written protest may be subsequently submitted. Only the team captain may submit verbal and written protests. Collective protests are not allowed.

No protests are accepted after the submission deadline passes.

A fee in the value of € 100 shall be paid with the submission of the written protest. If the protest is rejected, the fee is forfeited in favor of the IBSF. Otherwise, the protest fee is returned.

The decision regarding a protest submitted during a race shall be made in a timely manner to allow the team affected by the protest to potentially continue to participate in the race.

In cases of protests submitted after the conclusion of the race, the Jury will announce its decision no more than one hour after the submission of the protest, if possible.

The decision of the Jury is determined by a simple majority of votes. If the votes are equal, the Jury President casts the deciding vote. Jury Assistants do not have the right to vote.

The decision of the Jury is final, incontestable and takes effect immediately.

11. RANKING LISTS

11.1. Discipline Ranking List and Discipline Combined Ranking List of the Race Series

For the World Cup, Intercontinental Cup, Asian Cup, North American Cup, Europe Cup, the Youth and Women's Monobob Series a discipline Ranking List for men and women respectively, will be issued at the end of the season whereas the results in the particular race series based on the ranking list points (11.3) are added up. The winner of the overall WC/ICC/AC/EC/NAC/Youth/Women's Monobob Ranking List is the team with the most points

from the competitions in the particular race series. The first, second and third placed pilot in the overall ranking lists of each series, receive awards. In men's and women's bobsleigh; the first 3 pilots in the respective Combined Ranking List of each respective series also receive awards.

The World Cup Discipline Ranking List serves to determine the starting order for the World Championships.

The Discipline Ranking Lists and the Discipline Combined Ranking Lists will be updated after each race.

11.2. IBSF Discipline Ranking List and IBSF Combined Ranking List

The term "IBSF Ranking List" used hereunder refers to both the IBSF Discipline Ranking List and the IBSF Combined Ranking List unless otherwise described.

Principally only those pilots are listed in an IBSF Ranking List who are ranked at least in one race.

During the current season, the best results of each pilot are totaled by name for the IBSF Ranking List, regardless of the race series or World Championships in which the results were scored. The "Juniors" are highlighted.

For men's bobsleigh, there is an IBSF Ranking List for 2-man Bobsleigh, for the 4-man Bobsleigh and for a Combined IBSF Ranking List.

The IBSF Combined Ranking List includes only those pilots who are ranked in both 2-man and 4-man bobsleigh races.

The number of races to be considered for the IBSF Ranking List in men's bobsleigh corresponds to the number of World Cup races that are taken into account in the respective discipline at a specific time during the current season.

The number of races to be considered for the men's IBSF Combined Ranking List corresponds to the number of World Cup races that are taken into account in the respective discipline at a specific time during the current season.

For women's bobsleigh, there is an IBSF Ranking List for Women's Monobob, for 2-woman Bobsleigh and for the Combined IBSF Ranking List.

The IBSF Combined Ranking List includes only those pilots who are ranked in both Women's Monobob and 2-woman Bobsleigh races.

The number of races to be considered for the IBSF Ranking List in women's bobsleigh corresponds to the number of World Cup races that are taken into account in the respective discipline at a specific time during the current season.

The number of races to be considered for the women's IBSF Combined Ranking List corresponds to the number of World Cup races that are taken into account in the respective discipline at a specific time during the current season.

The IBSF Discipline Ranking Lists will be updated immediately after each race.

The IBSF Combined Ranking List serves to determine the quotas for men's and women's quotas for the Olympic Winter Games. For Women's Monobob an exception is applied which are detailed in the Olympic Qualification System of the respective Olympic Winter Games. .

The IBSF Discipline Ranking List (Women's Monobob, 2-woman Bobsleigh, 2-man Bobsleigh and 4-man Bobsleigh) serves to determine the starting order for the World Cup, Intercontinental Cup, Asian Cup, North American Cup and Europe Cup races of the current season as well as for the first competition for each Series of the following competition season. If the ICC, AC, NAC and or EC start before the WC the current Discipline Ranking List of the corresponding series will be used to determine the starting order.

The IBSF Discipline Ranking List serves to determine the quotas for the World Championships. The IBSF Combined Ranking List is meant to determine the Quota per Nation for the World Cup and the Intercontinental Cup of the following competition season.

During the World Championships the World Cup Points Table is applied, for the Junior World Championships the Points Table according to 11.3 is adopted.

The top-ranked teams of a nation determine the nation quotas for the World Cup competitions, and the next-ranked teams determine the quotas for the Intercontinental Cup competitions.

If a pilot sits out for a season, the pilot is scored with 50% of his points achieved on the IBSF Ranking List for the first race of the following season.

In cases of equal total points, the following criteria apply to define the position in the IBSF Ranking List:

- a) In general: The number of races scored is equal to the number of World Cup races carried out up to that specific date during the current season. The pilot with the highest individual number of points among all races considered is in the lead.
- b) In case of a tie according to item 1, the race immediately preceding and considered at the time of the issue of the IBSF ranking list is decisive, regardless of the number of points. This means that the pilot is in the lead, whose latest for the IBSF ranking considered race is the most recent.
- c) In case that the pilot concerned have obtained a result in the same most recent race considered according to item 2, the pilot with the better placement in the corresponding race is in the lead.
- d) In case of a tie according to item 3 (only possible if the pilot have an ex-aequo placement in the corresponding race), the procedure described in item 2 must be repeated, taking into account the next immediately preceding race.
- e) In case of a tie according to item 4, the position of the pilot concerned for the draw of the starting order of the race will be decided by lot.

11.3. IBSF Ranking List - Points

WC and WCh.		JWCh.		AC/EC/ NAC/ YOUTH series	
Rank	Points	Rank	Points	Rank	Points
1	225	1	120	1	120
2	210	2	110	2	110
3	200	3	102	3	102
4	192	4	96	4	96
5	184	5	92	5	92
6	176	6	88	6	88
7	168	7	84	7	84
8	160	8	80	8	80
9	152	9	76	9	76
10	144	10	72	10	72
11	136	11	68	11	68
12	128	12	64	12	64
13	120	13	60	13	60
14	112	14	56	14	56
15	104	15	52	15	52
16	96	16	48	16	48
17	88	17	44	17	44
18	80	18	40	18	40
19	74	19	37	19	37
20	68	20	34	20	34
21	62	21	31	21	31
22	56	22	28	22	28
23	50	23	25	23	25
24	45	24	22	24	22
25	40	25	20	25	20
26	36	26	18	26	18
27	32	27	16	27	16
28	28	28	14	28	14
29	24	29	12	29	12
30	20	30	10	30	10

12. BOBSLEIGH CONSTRUCTIONS WITH DRAWINGS

General

The contents of the text are binding; the dimensions indicated in the drawings, diagrams and figures are compulsory.

The term 2-man Bobsleigh determines the disciplines 2-man Bobsleigh and 2-woman Bobsleigh. Both the terms „bobsleigh“ and „bob“ are used to define the same system of frame, cowling and runners.

12.1. Principles and Properties

12.1.1. Purpose of the Rules of 12.1

The purpose of the rules of chapter 12 is to promote the safety of the athletes participating in training and competition and of those present at IBSF events and to uphold a fair and honest competition.

12.1.2. Principles

- a) Bobs have four runners (one pair of front runners and one pair of rear runners) and are used in competitions that are carried out on iced tracks.
- b) To propel the bob, only the pushing force of the team, when starting and the force of gravity are allowed.
- c) Three types of bobs are recognized: monobob (applies for the discipline Women’s Monobob), 2-man bob (applies for disciplines 2-man Bobsleigh as well as 2-woman Bobsleigh) and 4-man bob.
- d) Bobs must be cowled within the guidelines specified by these rules.
- e) The rear part of the bobs must be open.
- f) From the start (green light signal), no specifications of the bobs may be changed (damages excluded).
- g) The driver’s and side push bars must be fully retracted. Non-compliance may be punished.
- h) It must be possible for the Jury or IBSF Material Controller to check the specifications of all constructive elements (axles, runner carriers, steering mechanism, articulation mechanism, etc.) without great technical effort. If any sled component or assembly will be judged as not complying with the Rules, this is to be justified in writing by indication of the relevant regulation.
- i) During the course of IBSF events, the Jury may order checks on bobs and sports equipment.
- j) The bob manufacturers are responsible for the construction of sleds that can withstand, without damage, the stress of repeated heats on the bob tracks.
- k) For building bobs, it is forbidden to use transparent material, or any material that may shatter as a result of an impact.

- l) For the purpose of the IBSF, the term “steel” means an alloy of iron and carbon with an iron (Fe) content of more than 50% by weight, or an alloy which reacts positively to the IBSF approved testing device.
- m) No electronic, electric, electronically activated or wave activated components are allowed on the bob or the crew during official training or competition. The exceptions are those components approved by the IBSF and the relevant Jury.
- n) With the exception of liquids or liquid-like fluids used for the purpose of lubricating the bearings and bushings of the frame, no liquids or liquid-like materials may be held in the frame or cowling or may in any way be attached to the frame or the cowling during an official IBSF event.
- o) For the purpose of the IBSF, the terms rubber and/or rubber-like material mean a resilient material showing a hardness of less than Shore-D 100 on the ASTM D2240 Durometer test.
- p) The term ‘plate’ is to denote a flat component of sheet material having a uniform thickness.

12.1.3. Bobsleigh Properties

12.1.3.1. Bobsleigh Functional Dimensions

The following main dimensions and constructive elements of the bobs are fixed. All dimensions refer to bobs without any load on a flat surface, if not specified to the contrary.

12.1.3.1.1. Gauge (centre to centre of opposite runners).

The gauge is the same for the front and rear runners, 670 mm ± 1 mm.

12.1.3.1.2. Axle base

Distance from the centre of the front axle to the centre of the rear axle (referred to the plane of symmetry of the bob): 1690 mm ± 30 mm (2-man bob); 2130 mm ± 30 mm (4-man bob).

12.1.3.2. Bobsleigh Miscellaneous Properties

12.1.3.2.1. Bobsleigh Suspension

There must be no rubber, rubber-like or energy absorbing materials in the runner carriers, frame and / or all other parts of the bob, apart from those specifically allowed by the IBSF rules.

12.1.3.2.2. Bobsleigh Brakes

All bobs must be equipped with a functioning braking system (Figure 20).

12.1.3.2.3. Ballast

- a) Weight limit may be achieved by means of ballast. Ballast must be firmly welded or bolted or clamped to the sled by steel fastener. If ballast is not firmly welded or bolted or clamped to the sled by steel fasteners, it must be contained in a steel hollow profile. Such hollow

steel profile serving as a container for ballast must be firmly welded or bolted or clamped to the sled by steel fasteners. The size of any steel hollow profile serving as a container for ballast is limited to a cross-section of 50 x 50 mm and a length of maximally 400 mm. The use of tape or plastic straps (or cable ties) for the purpose of attaching any ballast to the sled is explicitly prohibited.

- b) No liquids or liquid-like materials may be used as ballast materials.

12.2. Bobsleigh Construction and Functioning

12.2.1. Purpose of Rules of 12.2

The purpose of the Rules governing the construction and functioning of the equipment used is to promote that the equipment used in IBSF events is able to withstand the stresses of training and competition and that the equipment used provides adequate protection for those using the equipment. Furthermore, the paragraph 12.2 aims to promote a fair and honest competition. Finally, 12.2 is directed at controlling the cost of competing in IBSF events.

12.2.2. General Structure and Functioning

12.2.2.1. Articulation

12.2.2.1.1. Transversal Division

Every bob frame must be divided transversally between front axle and rear axle.

12.2.2.1.2. Pivotal Connection

- a) The front portion and the rear portion of the bob are pivotally connected, the longitudinal pivot axis (2) being essentially parallel to the horizontal standing surface (1).
- b) The angle between said longitudinal pivot axis (2) and the horizontal standing surface is must not exceed 5°.

12.2.2.1.3. Longitudinal Pivot Axis

- a) The longitudinal pivot axis (2) is embodied by a longitudinal pivot bolt (3) of steel, having a middle circular cross-section with a minimum diameter of 30 mm (2-man bob) and 35 mm (4-man bob) that may taper to the ends to a minimum diameter of 21 mm (2-man bob) and 31 mm (4-man bob).
- b) By means of said bolt (3), both bob portions are pivotally connected.
- c) The pivot bolt (3) may have means of rotational elastic stabilization. For this purpose, rubber or rubber-like material may be used. These stabilizing elements must not contribute to any vertical movement. No hydraulic or pneumatic damping system is allowed.

- d) If the pivot bolt (3) ahead or behind the division is enclosed by a box, each box must have a 20 mm diameter inspection hole accessible from the top.
- e) At the dividing line, the longitudinal centerline of the longitudinal pivot axis (2) must be arranged at least 80 mm (2-man/2-woman and 4-man bobs, without crew and supported on runner carriers) above the standing surface.
- f) The dividing line must be at a distance of 520 mm \pm 50 mm (2-man/2-woman and 4-man bobs) behind the centre of the front axle.

12.2.2.1.4. Cowling division

The cowling must also be divided transversally. Rubber or rubber-like material may be used to cover the gap between the front and the rear parts of the cowling.

12.2.3. Frame and Running Gear

12.2.3.1. Purpose of the Rules of 12.2.3

The purpose of paragraph 12.2.3 is to control the sturdiness of the frame in the interest of safety and, in the interest of competition to control the amount of suspension provided to bobsleigh.

12.2.3.2. General Stipulations Frame

- a) All joints in the frame must be rigid.
- b) The front (4) and rear (31) frame must not be adjustable in stiffness during heats or between heats.

12.2.3.3. Front Portion of the Frame

- a) The front portion of the bob must be constructed with a continuous (welded) supporting frame (4) made of steel and extending from the longitudinal bolt (3) at the transversal division line to the bearing housing of the steering bolt (5). All load bearing frame members and the bearing housing(s) of the steering bolt (5) and the bearing housing(s) of the longitudinal bolt (3) bolt must be welded to the frame.
- b) The swivel angle of the front axle (9) (2-man/2-woman and 4-man bobs) in the vertical plane (referred to the standing surface) is limited to maximally $\pm 12^\circ$
- c) The distance from the centre of the front axle (9) to the front tip of the bob is limited to: minimally - 600 mm (2-man/2-woman and 4-man bobs) and maximally - 750 mm (2-man/2-woman and 4-man bobs)
- d) If the frame members and connecting profiles are made of tubing, they must remain hollow with no filling and have an inspection hole with a minimum diameter of 8 mm.

12.2.3.3.1. Steering mechanism

- a) A rotating steel steering bolt (5) is fitted to the front frame (4) and rotates by means of a steering mechanism. The said steering bolt must not exceed 5° from vertical.
- b) The bearing housing of the steering bolt must be completely welded to the frame, on all sides.
- c) The lower end of the steering bolt is fully welded to a steel steering plate (6) perpendicular to the steering bolt, which must have a minimum thickness of 7.5 mm over its entire surface and a minimum width of 69 mm over half its length (2-man and 4-man bobs). A central access hole is allowed. In addition four maximum 10 mm holes on each side are allowed only to attach the steering stop and the brackets. Other holes are prohibited.
- d) On this steering plate (6), at a bolt (7) lying in front of the axle (9) and at a bolt (8) lying behind the axle (9), steel flanges (11a and 11b) are pivoted on a pivot axis (10) that is perpendicular to the front axle (9) and perpendicular to the steering bolt (5).
- e) The minimum diameter of the bolts (7 and 8) must be 20 mm.
- f) There must be no vertical motion between the fixed bearing and the rotating support.
- g) A continuous, one-piece steel bottom plate (14) is mounted below the axle (9) with a minimum thickness of 7.5 mm (2-man/2-woman and 4-man bobs) throughout the surface of the plate and a minimum width of 69 mm (2-man/2-woman and 4-man bobs). On each end of the plate for a length of 20 mm a chamfer or rounding is allowed. The bottom plate 14 may be bent over a lateral axis not more than two times.
- h) The bottom plate (14) is firmly bolted (15), with no free play, to both steel flanges (11a, 11b) with a continuous basic thread and a torque of at least 25 NM for M8 and 45 NM for M10 (15). Minimum two bolts each side with minimum M8. Movement of the steel flanges relative to the bottom plate (11a and 11b) is not allowed.
- i) No rubber may be placed between the respective flanges (11a, 11b) and the bottom plate in accordance with figure 9a and 15a.
- j) For any further compensation, only steel and / or aluminum shims may be used.
- k) The free length of the bottom plate (14) between the two flanges (11a and 11b) in the longitudinal direction of the bob is 220 mm ± 40 mm (2-man/2-woman and 4-man bobs).
- l) The flanges (11a and 11b) can be provided with U-shaped guiding elements.

- m) For the purpose of returning the runners in a neutral position, rubber or rubber-like materials may be used in the steering mechanism.

12.2.3.3.2. Front Axle

- a) The front axle (9) consists of a continuous, straight, circular steel tube manufactured from a single piece of steel having a diameter 45 mm +/- 1 mm (2-man/2-woman and 4-man bobs), which reduces to a minimum of 32 mm (2-man/2-woman and 4-man bobs) to fit the bearing of the front runner carrier (17).
- b) The 45 mm +/-1 mm diameter portion of the axle must have a minimum wall thickness of 9 mm and a minimal length of 450 mm.
- c) In its middle portion, the front axle (9) has a steel fastening plate (18) having a width 95 mm (+/- 26 mm), a length of 70 mm (+/- 20 mm) and a thickness of 9 mm (+/- 1,5 mm) that must be strongly welded (not screwed) to it and firmly bolted to the bottom plate (14) by at least 4 bolts with a core diameter of at least 6,5 mm.
- d) Steel spacers are allowed between the axle fastening plate and the bottom plate.
- e) The fastening plate (18) may be recessed flush to the circumference of the front axle (9).
- f) A steel plug may be welded or pressed into each end of the axle (9) to provide attachment for the runner carrier retainer.
- g) If a steel plug is used in the end of the axle, it must have a through-hole with a minimum diameter of 8.5 mm.
- h) The front axle (9) must not be clad, cased or streamlined.
- i) No additional holes and reinforcements may be permitted. At the end of the axle only two additional holes can be made to fix steel pins.

12.2.3.3.3. Front Axle Leaf Spring

- a) Between the steering plate (6) and the front axle (9) there is a continuous steel leaf spring (19) with a minimum thickness throughout of 6 mm.
- b) The points at which the leaf spring (19) rests on the front axle (9) must be symmetrically at least 330 mm from each other (2-man/2-woman and 4-man bobs).
 1. The leaf spring can be made of three pieces.
 2. The brackets must have an axial width of min. 12 mm. The brackets must be screwed with a minimum number of two M8 screws.
 3. The radius of the brackets will not be limited.

4. Steel spacers with full contact area are allowed between spring plate and bracket. The spacer must have the same area as the brackets.
5. Brackets must be made of steel.

When the axle is in a neutral position, there must be no free play between the leaf spring (19) and the steering plate (6) or between the leaf spring (19) and the axle (9).

No spacers are allowed between the leaf spring (19) and the steering plate (6) or between the leaf spring (19) and the axle (9).

12.2.3.3.4. Front Runner Carriers

- a) Each front-runner carrier consists of a straight steel spring leaf (17) with a thickness of no less than 7.5 mm throughout (2-man/2-woman and 4-man bobs).
- b) The distance from the standing surface of the front runner carriers to the axle centre is limited to maximally 100 mm.
- c) A bearing housing (16) for the front axle (9) must be welded to the upper side of the spring leaf (17).
- d) On the lower part of the spring leaf (17) there will be a guiding bracket (21) welded in the centre.
- e) On either end of the spring leaf (17) there will be holding brackets (22 and 23) welded in position.
- f) The bearing housing (16) has a minimum outside diameter of 50 mm (2-man/2-woman and 4-man bobs) and a maximum outside diameter of 55 mm (2-man/2-woman and 4-man bobs).
- g) The length of the bearing housing (16) is no less than 94 mm (2-man/2-woman and 4-man bobs).
- h) The hole in the bearing housing (16) must be concentric with respect to a horizontal diameter.
- i) The distance from the outer end of the bearing housing (16) to the straight outer edge of the front-runner carrier (17) must not exceed 6 mm.
- j) As seen in the top view, the outer side of the front-runner carrier (17) must be straight and perpendicular to the axle (9); the outer side of the spring leaf and guiding bracket must essentially fall above one another (No offset is allowed).
- k) The length of the front-runner carrier (17) is 655 mm \pm 3 mm (2-man bob), 735 mm \pm 3 mm (4-man bob).
- l) The width of the front-runner carrier (17) must be no less than 35 mm (2-man/2-woman and 4-man bobs) at the front and rear ends and must increase towards the centre to its maximum width, which

- must be no less than 69 mm (2-man bob) and no less than 89 mm (4-man bob).
- m) In a top view, the inside edge of the front-runner carrier (17) facing the cowling must not be concave.
 - n) The front and rear holding brackets (22 and 23) have a U-shaped cross section, where the “bridge” of the U is welded to the runner carrier (17) and has a minimum thickness of 7.5 mm.
 - o) The two U legs extend vertically downward with a height of 50 mm \pm 2 mm. The outside dimensions of the U legs are 30 mm \pm 2 mm.
 - p) The length of the holding brackets (22 and 23) is 70 mm \pm 2 mm.
 - q) The holding brackets (22 and 23) must be provided with runner mounting holes, the centre of which must be 31 mm \pm 1 mm from the lower side of the runner carrier (17). The runner mounting holes must be symmetrical within 1 mm to the front and rear of the holding brackets (22 and 23).
 - r) Only the holes (24 and 25) for the head of the bolts may be countersunk.
 - s) The hole centers of the front and rear holding brackets (22 and 23) have a centre distance of 585 mm \pm 2 mm (2-man bob) and 665 mm \pm 2 mm (4-man bob).
 - t) The middle guiding bracket (21) has the same dimensions as the holding brackets (22 and 23), with the exception that the U legs are connected by welded metal straps, front and rear, to hold a layer of rubber or rubber-like material at the bottom of the U (26).
 - u) The middle guiding bracket (21) may be additionally supported to the spring leaf.
 - v) The centre of the bearing housing (16) may be a maximum of 5 mm out of symmetry between the runner mounting holes (2-man/2-woman and 4-man bobs).
 - w) The runner carriers (17) must have a means of rotational elastic stabilization.
 - x) If the rotational stabilization is mounted from the bottom of the runner carrier, the opening in the spring leaf may not exceed a length of 35 mm and must be within the welds of the bushing to the spring leaf.
 - y) The front-runner carriers (17) must not be cased, clad, faired or streamlined.
 - z) All edges of the spring leaf, guiding brackets (21) and holding brackets (22 and 23) may be radiused or chamfered to a maximum of 8 mm.

12.2.3.4. Rear Portion of the Frame

- a) The rear bob portion must be constructed with a continuous (welded) supporting frame (31), made of steel and extending from the longitudinal pivot bolt (3) at the transversal division line to the fastening means for the rear axle. All load bearing frame members and the bearing housing(s) of the longitudinal bolt (3) must be welded to the frame.
- b) From the division line to 330mm behind the rear axle, the longitudinal frame members must be made of closed steel profile must be tightly welded around entire diameter and from all sides to the fastening means of the rear axle. The longitudinal frame members must have a minimum section area of 703 mm²; the largest dimension of the said frame member must be at least 37 mm. The smallest dimension of the said frame member must be at least 19 mm. The longitudinal frame members may be extended by 330mm behind the rear axle. The rear part of the frame must not be adjustable in geometry and stiffness at any time.
- c) If the longitudinal members are made of tubing, they must remain open with no filling. Inspection holes with a minimum diameter of 9 mm must be located at the division box towards the rear axle as well as at the end of the rear portion of the frame, so that an inspection of the frame with a camera is possible.
- d) The minimum distance between the two longitudinal members of the rear frame will be 320 mm.
- e) Where the axle is fastened to the rear frame, there will be a defined contact area between the axle mounts and the axle. In any case the contact area between the axle and each axle mount must be at least 700 mm².
- f) In case the axle is fastened to the frame by means of bolts, full contact between the axle and the axle mounts must exist for a distance of a minimum of 15 mm around the fastening hole.
- g) In case the axle is fastened to the frame by means of clamps, full contact between the axle and the axle mounts must exist over at least 150 degrees of the circumference of the axle and over a length of at least 25 mm.
- h) The minimum distance between the bolt connections will be 165 mm. The axle must be firmly bolted to the axle mount. No movement between the axle and the axle mount is allowed.

12.2.3.5. Intentionally left blank

12.2.3.6. Rear Axle

- a) The rear axle (27) consists of a continuous, straight, circular steel tube manufactured from a single piece of steel having an outer diameter that is 45 mm (+/- 1 mm) (2-man/2-woman and 4-man

- bobs), which reduces to a minimum of 32 mm (2-man bob) and 34 mm (4-man bob) to fit the bearing (28) of the rear runner carrier (29).
- b) The 44 mm diameter portion of the axle must have a minimum wall thickness of 9 mm and a minimum length of 450 mm.
 - c) The rear axle (27) must be firmly bolted to the rear frame (31) without any resilient or shock absorbing material in between. Horizontal bolts are not permitted.
 - d) Steel spacers are allowed. Steel spacers must have permanent contact surface of 700 mm² on each side to reach correct geometry only, without additional elements that perform some other function.
 - e) The rear axle (27) can be bolted either above or below the rear frame (31) (2-man/2-woman and 4-man bobs). The bolt connection has a minimum distance of 165 mm.
 - f) A steel plug may be welded or pressed into each end of the axle to provide attachment for the runner carrier retainer.
 - g) If a steel plug is used in the end of the axle, it must have a 6.5 mm through-hole.
 - h) The rear axle (27) must not be clad, cased or streamlined.
 - i) Material control can be done at any time and in any position.

12.2.3.6.1. Intentionally left blank

12.2.3.6.2. Runner Carriers

- a) Each rear runner carrier consists of an upper and lower straight steel spring leaf (32 and 33) with a thickness of no less than 7.5 mm throughout (2-man/2-woman and 4-man bobs).
- b) The vertical distance from the standing surface of the rear runner carriers to the axle centre is limited to maximally 110 mm.
- c) A bearing housing (28) for the rear axle must be welded to the upper side of the upper spring leaf (32).
- d) On the lower side of the lower spring leaf (33) there will be a guiding bracket (34) welded in the centre.
- e) On either end of the lower spring leaf (33) there will be holding brackets (35 and 36) welded in position.
- f) The bearing housing (28) has a minimum outside diameter of 50 mm (2-man/2-woman and 4-man bobs) and a maximum outside diameter of 55 mm (2-man bob) and 57mm (4-man bob).
- g) The length of the bearing housing (28) is no less than 94 mm (2-man/2-woman and 4-man bobs).
- h) The hole in the bearing housing (28) must be concentric with respect to a horizontal diameter.

- i) The distance from the outer end of the bearing housing (28) to the straight outer edge of the upper spring leaf (32) must not exceed 6 mm.
- j) As seen in the top view, the outer side of the lower spring leaf (33) must be straight and is essentially perpendicular to the axle (27); at the centre of the runner carrier, the outer side of the upper spring leaf (32), lower spring leaf (33) and guiding bracket must essentially fall above one another. (No offset is allowed.)
- k) The length of the lower spring leaf (33) is 813 mm \pm 3mm (2-man bob) and 940 mm \pm 3 mm (4-man bob).
- l) The width of the lower spring leaf (33) must be no less than 35 mm (2-man/2-woman and 4-man bobs) at the front and rear ends and must increase towards the centre to its maximum width, which must be no less than 79 mm (2-man bob) and no less than 89 mm (4-man bob).
- m) In a top view, the inside edge of the lower spring leaf (33) facing the cowling must not be concave.
- n) The front and rear holding brackets (35 and 36) have a U-shaped cross section, where the bridge of the U is welded to the lower spring leaf (33) and has a minimum thickness of 7.5 mm.
 - a. The two U legs must extend vertically downward with a height of 50 mm \pm 2 mm.
 - b. The outside dimensions of the U legs must be 30 mm \pm 2 mm.
- o) The length of the holding brackets (35 and 36) must be 70 mm \pm 2 mm.
- p) The holding brackets (35 and 36) must be provided with runner mounting holes, the centre of which must be 31 mm \pm 1 mm from the lower side of the spring leaf (33). The runner mounting holes must be symmetrical within 1 mm to the front and rear of the holding brackets (22 and 23).
- q) Only the holes (35 and 36) for the head of the bolts may be countersunk.
- r) The hole centers of the front and rear holding brackets (35 and 36) must have a centre distance of 743 mm \pm 2 mm (2-man bob) and 870 mm \pm 2 mm (4-man bob).
- s) The middle guiding bracket (34) has the same dimensions as the holding brackets (35 and 36), with the exception that the U legs are connected by welded metal straps, front and rear, to hold a layer of rubber or rubber-like material at the bottom of the U (34).
- t) The middle guiding bracket (34) may be additionally supported to the spring leaf (33).

- u) The centre of the bearing housing (28) may be a maximum of 5 mm out of symmetry between the runner mounting holes (2-man/2-woman and 4-man bobs).
- v) The upper spring leaf (32) is shorter than the lower spring leaf (33) and has a length of 480 mm \pm 3 mm (2-man bob) and 590 mm \pm 3 mm (4-man bob).
- w) The minimum width at the front and rear ends of the upper spring leaf (32) is 40 mm and must increase towards the centre to its maximum width, which must be no less than 79 mm (2-man bob) and 89 mm (4-man bob).
- x) In the top view, the upper spring leaf must have no concave edges.
- y) The upper (32) and lower (33) spring leafs lie flat on one another and are bolted together by no less than 6 and no more than 8 bolts with hexagonal nuts.
- z) There must be the same number of bolts on either side of the bearing housing (28).
 - a. Only the holes for the head of the bolts may be countersunk.
 - b. The minimum diameter of the bolts must be 12 mm (2-man bob) and 14 mm (4-man bob).
 - c. The minimum height of the hexagonal nuts must be 10 mm (2-man bob) and 11 mm (4-man bob).
- aa) The runner carriers (29) must have a means of rotational elastic stabilization. If the rotational stabilization is mounted from the bottom of the runner carrier, the opening in the spring leaf may not exceed a length of 35 mm and must be within the welds of the bushing to the spring leaf.
- bb) The runner carrier (29) must not be cased, clad, faired or streamlined.
- cc) All edges of the spring leafs (32 and 33), guiding brackets (34) and holding brackets (35 and 36) may be radiused or chamfered to a maximum of 8 mm.

12.2.4. Cowling

12.2.4.1. Purpose of 12.2.4

The purpose of paragraph 12.2.4 is to promote the safety of the athletes competing in IBSF events by attempting to ensure that the cowling of a bobsleigh will provide sufficient protection in case of crashes. Furthermore, the Rules of 12.2.4 aim to promote a competition without unfair aerodynamic advantages.

12.2.4.2. General Cowling Stipulations

- a) The brake cut-out must be open.
- b) No attempt may be made to reduce the area of the cut-out with any material, **except padding in accordance with rule point 12.2.8.7 Padding Materials.**
- c) Any unusual additions to the shape that are clearly vortex generators are not allowed.
- d) Additional holes that may give an improved aerodynamic effect are also not allowed.
- e) The cowling provides adequate protection for the athletes.

12.2.4.3. Cowling Dimensions

12.2.4.3.1. Cowling Width, 2-man Bobsleigh

The distance from the farthest point to the opposite farthest point (measured on the horizontal plane according to Figure 2 of the drawings) must be:

- a) At a distance of 1200 mm in front of the centre line of the rear axle: minimally - 680 mm.
- b) At a distance of 600 mm from the centre line of the rear axle: minimally - 640 mm.
- c) At the centre line of the rear axle: minimally - 540 mm.

12.2.4.3.2. Cowling Width, 4-man Bobsleigh

From the centerline of the rear axle up to a distance of 1600 mm in front of the centerline of the rear axle, a constant minimum width of 700 mm must be maintained.

12.2.4.3.3. Inside Cowling Width 2-man and 4-man Bobsleigh

Measured at a height of 400 mm from the bottom of the bob, at the beginning of the cowling cut-out, the inside cowling width must be minimally 550 mm (2-man and 4-man Bobsleigh).

12.2.4.3.4. Cowling Height

- a) The cut-out must be minimally 650 mm (2-man/2-woman and 4-man bobs).

12.2.4.3.5. Cowling Side Region

- a) The side cowling, from the region of the driver's shoulders to the centre of the rear axle, must not be higher than 650 mm as measured from the bob bottom and must have a minimum height of 580 mm.
- b) The cowling must be open – starting from the region of the driver's shoulders, through to the back.

- c) The width of the opening, starting 500 mm behind the beginning of the opening to the rear axle centre, must be minimally 450 mm down to a depth of 300 mm (2-man/2-woman and 4-man bobs).
- d) From the centre of the rear axle to the hindmost point of the bob, the width of the opening must be minimally 400 mm measured down to a point 300 mm above the lowest point of the bottom of the bob (2-man/2-woman and 4-man bobs).

12.2.4.3.6. Cowling Miscellaneous

- a) From the highest part of the driver's cut-out, there must be a vertical flange as shown in Figure 4. The vertical flange must be a minimum height of 30 mm in the centre of the driver's cut-out. The flange may taper down to the thickness of the cowl over a distance of 100 mm on either side of centre.
- b) The rectangular, symmetrical inspection hole situated beneath the front axle must be at least 440 mm long and at least 160 mm wide.
- c) On either side, a rubber or rubber-like membrane may be used to close the gap between the front axle and the cut-out for the front axle.
- d) On the top of the brake housing, a rubber or rubber-like membrane may be used around the handles.

12.2.4.4. Cowling Shapes

12.2.4.4.1. Purpose of 12.2.4.4

The purpose of paragraph 12.2.4.4 is to promote a competition without unfair aerodynamic advantages.

12.2.4.4.2. Convex Surfaces

The cowling shape must be convex in the following areas:

- a) From the front of the bob to the driver cut-out, every intersection line between a rotating cutting plane and the cowling, refer to Figure 3A.
- b) From the front of the bob to the rear of the bob, every intersection line between the vertical cutting planes and the cowling above the widest point or at least above the bumpers, refer to Figure 3B.
- c) From the beginning of the driver's cut-out to the rear of the bob, the intersection line between a horizontal cutting plane and the cowling, at a height of 350 mm above the standing surface of the runner carriers, refer to Figure 3C.
- d) On the bottom of the bob, every intersection line between a longitudinal vertical cutting plane as well as every intersection line between a perpendicular vertical cutting plane and a 240 mm wide symmetric band centered on the bottom of the bob. Outside of the

240 mm band, the only exceptions would be the impressions created for the runner and the runner carrier clearance, refer to Figure 3D.

The following exceptions apply:

- a) The bumpers (front and back)
- b) The brake cut-out
- c) The impression for the driver's push handle
- d) The articulation joint
- e) The holes for the front and back axles
- f) The transition from the side push bar into the main body of the cowling (fig.7)
 - a. if the pushbars are mounted directly to the top of the side of the main body of the cowling: From a vertical plane 450 mm forward of the axis of rotation and a height of 670 mm above the standing surface of the runner carriers.
 - b. if the pushbars are mounted to a separate stanchion intersecting the main body of the cowling: In a radius of 400 mm from the center at the top of the axis of rotation of the push bar.
- g) & h) The area around the brakeman's push handles that is within a radius of 250 mm from the point of the brakeman's push handles farthest removed from the centerline of the rear axle.

12.2.5. Connection between Frame and Cowling

12.2.5.1. Purpose of 12.2.5

The purpose of 12.2.5 is to control the amount of suspension that can be achieved in the connections between cowling and frame.

12.2.5.2. Definition of Connection between Cowling and Frame

All elements that mechanically attach the cowling as defined and controlled by 12.2.4 to the frame as defined and controlled by 12.2.3 are considered to jointly form the connection between cowling and frame and to be controlled by 12.2.5.

12.2.5.3. General Stipulations

- a) Any measurements with regard to travel of the cowling relative to the frame are relative to the horizontal plane of reference, with the bobsleigh in an unloaded condition.
- b) Within the context of 12.2.5, the term 'downward' is used with reference to the unloaded condition of the bobsleigh while positioned on a horizontal reference plane.
- c) Within the context of 12.2.5, the limitation of freedom of movement of the cowling relative to the frame is defined with reference to the unloaded

condition of the bobsleigh while positioned on a horizontal reference plane.

- d) Article 12.1.3.3.1 (Bobsleigh suspension) applies.

12.2.5.4. Locations of points of mounting of Cowling to Frame

- a) The cowling must be attached to the frame by means of four (2-man) and a maximum of eight (4-man) mounting brackets that to restrict the vertical movement of the cowling relative to the frame. No additional mounting means allowed.
- b) Two of these four mounting brackets must be positioned symmetrically relative to the plane of symmetry of the bob, in a vertical plane that is perpendicular to the plane of symmetry of the bobsleigh and within 100 mm of most forward part of the rear part of the frame excluding the articulation bolt (Figure 23).
- c) Two of the rear mounting brackets must be positioned symmetrically relative to the plane of symmetry within 330 mm backward and 120mm forward of the centerline of the rear axle of the bob and must be mounted on or to the outside of the longitudinal frame member. If the base of the fastening brackets is not glued to the cowling, but screwed, then the screws must not move and this connection must not move (Figure 23).

12.2.5.5. Freedom of Movement of Cowling relative to Frame

- a) The movement of the cowling relative to the frame, allowed by the fastening brackets of the cowling controlled by 12.2.5.4 and 12.2.5.6 must be limited to 5 mm in the downward direction by use of travel stops.
- b) Irrespective of the suspension elements used within the context of 12.2.5.4 and 12.2.5.6, the travel of these suspension elements must be limited by hard travel stops of sufficient rigidity to guarantee effective limitation of cowling movement.
- c) The forward travel stops limiting the vertical movement of the cowling must be fully positioned within the confines of 12.2.5.4. Travel stops must be integral part of mounting bracket.
- d) The rear travel stops must be mounted on or to the outside of the longitudinal frame member and completely within 120 mm forward and backward of the centerline of the rear axle (Figure 23 - still valid including the 2025/2026 season for AC, EC and NAC).
- e) The rear travel stops must be integral part of the fastening bracket mounted on or to the outside of the longitudinal frame member and completely within 330 mm backwards and 120 mm forward of the centerline of the rear axle (Figure 23).

12.2.5.6. Materials used in Cowling to frame Connection

- a) In the mounts between the cowling and the frame, rubber or rubber-like material may be used.
- b) The rubber or rubber-like material used in the connection between frame and cowling must be homogeneous.

12.2.6. Bumpers

12.2.6.1. Purpose of 12.2.6

The purpose of 12.2.6 is to attempt to ensure that the elements of the bobsleigh that come into contact with the walls of the track are suitable for that purpose. Furthermore, 12.2.6 aims to promote that no unfair aerodynamic advantages can be achieved. Finally art. 12.2.6. is directed to preserve the integrity of the track.

12.2.6.2. General Stipulations

It is the responsibility of the bob manufacturers to produce the bumpers with sufficient strength to withstand repeated contact with the walls.

12.2.6.3. Bumper Positions and Dimensions

- a) The front tips of the front-runners must be covered by the cowling in any position of the runners.
- b) Distance from the standing surface of the runner carriers to the lower edge of the bumpers is limited to:
 - a. Front bumpers:
 - maximally 190 mm (2-man bob);
 - maximally 200 mm (4-man bob);
 - b. Rear bumpers:
 - maximally 200 mm (2-man bob and 4-man bob).
- c) The rear bumpers must have a minimum height of 50 mm (measurement taken vertically with regard to the standing surface) over a length of minimum 200 mm.

The rear bumpers must not exceed a maximum length of 600 mm in the two-man/two woman bob and 900 mm in the four-man bob (measured from the rearmost point of the bumper).
- d) The centre of the front bumpers, referring to a length of 300 mm, must be at least 300 mm from the centre of the front axle (2-man/2-woman and 4-man bobs).

The front bumpers may have a maximum length of 1000 mm (measured from the foremost point of the bobsled cowling).
- e) Above the front bumper 300 mm forward from the centre of the front axle, the distance from the outside of the bumper to the cowling, measured horizontally and perpendicular to the centre line of the bob, must not

exceed 195 mm (2-man/2-woman bob) and 160 mm (4-man bob), refer to Figure 2.

- f) The distance from the farthest point of one bumper to the farthest point of the opposite bumper must be:
 - a. Front:
 - 860 mm \pm 10 mm (2-man bob);
 - 870 mm \pm 10 mm (4-man bob).
 - b. Rear:
 - Minimally 800 mm (2-man bob).
 - Minimally 830 mm (4-man bob).
- g) The distance from the centre of the rear axle (27) to the hindmost point of the rear bumper must be:
 - a. Minimally - 300 mm (2-man/2-woman and 4-man bobs);

12.2.6.4. Maximally - 760 mm (2-man/2-woman and 4-man bobs). Bumper Shapes

- a) The upper and lower edges of the rear bumpers must have a radius of between 5 and 8 mm.
- b) The lower edge of the front bumpers (Figure 5) must have a radius of no less than 10 mm for a minimum length of 300 mm. In an upward direction they must be straight for a minimum length of 35 mm, subsequently passing into the upper edge with a minimum radius of 35 mm.
- c) The point at which the bumper contacts the wall must be within the defined minimum length of the bumper. In a top view, the bumpers must be arc-shaped with a minimum radius of 200 mm for a distance of 100 mm ahead and behind the widest part of the bumper area (Figure 6).

12.2.6.5. Transitions to Cowling

- a) The connecting elements between the front bumpers and the bob cowling must have a height of a minimum of 80 mm over the minimal length of the front bumpers.
- b) The connecting elements between the rear bumpers and the cowling must have a height of a minimum of 50 mm over the minimal length of the rear bumpers.
- c) In a top view and in a side view the front of the connecting elements of the front bumpers must form a continuous, not concave line with the tip of the cowling.

12.2.7. Runners

12.2.7.1. Purpose of 12.2.7

Purpose of 12.2.7 is to promote a fair competition while controlling the costs of participating and administering in IBSF events by banning the use of exotic materials and (surface) treatments.

12.2.7.2. Runner material

- a) All runners must be produced in a solid piece of standard material according to IBSF specifications and must not exceed the hardness of 385 Brinell (HB).
- b) The material specifications, selected by the IBSF, will guarantee that all pre-machined pieces of steel are the same.
- c) The standard material is produced and distributed by a factory designated by the IBSF
- d) The material is supplied in the form of a pre-machined section, i.e. a section that has been ground on both sides, one of which is marked.
- e) The marking must always be present on the runners without being changed in any way.

12.2.7.3. Runner Treatment

- a) All types of treatment are forbidden, including those that even cause only a local variation of the physical characteristics and/or the composition and/or the structure of the material.
- b) No plating and/or coating is allowed.

12.2.7.4. Runner Dimensions

- a) The height of the steel body, between the front and rear fastening brackets, must be a minimum of 35 mm (2-man bob) and a minimum of 40 mm (4-man bob).
- b) The forward portion of the runner from 50 mm behind the tip to the front of the front fastening bracket must be no less than 29 mm high (2-man/2-woman and 4-man bobs).
- c) The front tip of the runner, in the side view, must have a minimum radius of 10 mm (2- and 4-man bobs).
- d) The top of the front-runner tip must be a minimum of 57mm above the standing surface.
- e) The rear lower tip of the runner must have a minimum radius of 50 mm (2-man/2-woman and 4-man bobs).
- f) At a distance of 10 mm from the rear tip of the runner, the lower surface must be a minimum of 25 mm above the standing surface (2-man/2-woman and 4-man bobs).

- g) The distance from the front tip of a front runner to the centre of the middle supporting bracket must be 500 mm \pm 30 mm (2-man/2-woman bob) and 540 mm \pm 30 mm (4-man bob).
- h) The overall length of the rear runners must not exceed 1200 mm (2-man/2-woman bob) and 1300 mm (4-man bob).
- i) The top surface of the middle supporting bracket must be flat and horizontal and must form a rectangle, minimum width 13 mm, minimum length 60 mm. The 60 mm dimension must be maintained down to the top of the runner.
- j) The top of the middle supporting bracket must be a minimum of 15 mm above the top of the runner.
- k) At the intersections of the middle supporting bracket with the top surface of the runner, there must be a minimum radius of 2 mm.
- l) The runner must have a thickness of 14 mm \pm 1 mm (2-man/2-woman and 4-man bobs). This thickness must be maintained for a minimum distance of 10 mm from the top of the runner.
- m) The cross-sectional radius of the runner, at the running surface, must be a minimum of 4 mm and a maximum of 7,5 mm (2-man bob) and a minimum of 6 mm and a maximum of 7,5 mm (4-man bob). This radius will be measured over 120° and will correspond to an arc height of 2 mm (2-man/2-woman bob) and 3 mm (4-man bob). The radius of the runners must be maintained over the full length of the runner with the exception of the 2 cm (measured horizontally – Fig. 21) at the extremes of the runner.
- n) The fastening brackets must have a minimum length of 60 mm (2-man/2-woman and 4-man bobs) measured at a height even with the upper edge of the runner.
- o) The area surrounding the mounting hole must maintain a minimum thickness of 10 mm to the periphery of the fastening bracket. **The transition area between the running surface and the full runner thickness must not be globally concaved.**
- p) The mounting holes are at a minimum distance of 33 mm and a maximum of 60 mm (2-man/2-woman bob) and a minimum of 38 mm and a maximum of 65 mm (4-man bob) from the bottom surface of the runner.

12.2.7.5. Connection between Runners and Runner Carriers

- a) The runners must be attached to the runner carriers using minimally 14 mm thread (2-man/2-woman bob) and minimally 16 mm thread (4-man bob) bolts with hexagonal nuts.
- b) No portion of the bolt may be smaller in diameter than 12.5 mm. (2-man/2-woman) and 14.5 mm. (4-man)
- c) It must be a self-locking nut with minimum height of 11 mm (2-man/2-woman bob) and of 13mm (4-man bob).

- d) The nuts must not be welded to the holding brackets of the runner carriers and they must not be cased, clad or streamlined.

12.2.7.6. Runners Miscellaneous

- a) The runner is shown in Figure 21.
- b) Any aerodynamic covering of the runners is prohibited.

12.2.8. Detachable, moveable and/or adjustable parts

12.2.8.1. Purpose of 12.2.8

The purpose of 12.2.8 is to promote that the detachable, movable and/or adjustable parts of a bobsleigh are suitable for their intended purpose and do not pose a risk for bystanders and/or those participating in IBSF events. Also, the purpose of art. 12.2.8. is to promote a fair competition.

12.2.8.2. Brakes

- a) Only harrow type brakes are allowed.
- b) The brake cut-out must be open. A rubber membrane around the brake handles may be used.
- c) No attempt may be made to reduce the area of the cut-out with any material.
- d) The brake is actuated with two separately activated handles. In a four-men bob, the handles must be located either side of the brakeman.
- e) The geometry of the brake must be designed in such a way that when applied by a single handle, with a full team complement, none of the brake components are permanently deformed (Figure 20).
- f) The length of the handle, measured from the centre of the pivot, must be minimum 220 mm (2-man bob) or 350 mm (4-man bob).
- g) The length of the braking arm measured from the centre of the pivot to the top of the harrow must be minimum 150 mm (2-man/2-woman and 4-man bobs).
- h) The height of the harrow must be minimum 35 mm (2-man/2-woman and 4-man bobs).
- i) The height of the teeth of the harrow must be minimum 20 mm (2-man/2-woman and 4-man bobs).
- j) There will be a minimum of 5 teeth over a total minimum length of 230 mm (2-man/2-woman bob) and a minimum of 6 teeth over a total minimum length of 280 mm (4-man bob).
- k) The teeth must be able to reach and cut the ice for a minimum of 50 mm below the runner standing surface.
- l) Rubber or rubber-like material may be used in the retraction mechanism of the brakes.

12.2.8.3. Push bars

- a) Both the driver's side push bar and the side push bars must be retractable.
- b) When retracted, the side push bars must be essentially flush with the surface of the cowling. The rotation axis has to have the same level in the extended and retracted positions.
- c) The brakeman's handles must be immovable.
- d) The brakeman's push handles (2-man/2-woman and 4-man bobs) as well as the side push bars (4-man bob) must have a minimum height of 670 mm and a maximum height of 870 mm, measured from the standing surface of the runner carriers.
- e) The total width of the side push bars (4-man bob) for the second and third members must not exceed 750 mm.
- f) When the four-men bob side push bars have a vertical rotating axis, the push bar stanchion must be at least two-thirds the width of the push bar, for at least two-thirds of the push bar length with a maximum gap of 3 mm.
- g) The front of the push bar stanchion tapers down to the cowling at a point not more than 450 mm ahead of the axis of the push bar (Figure 7).
- h) For the purpose of retracting the push bar(s), rubber or rubber-like materials may be used.
- i) The push bars (2-man/2-woman and 4-man position 2 respectively 4) must be at least 10 mm wide. The push bars position 2/4 have to have a width of 10mm at the length of 50 mm on their highest point (Fig. 1a). A transition area of 20 mm is allowed, where the width changes from 10 mm to cowling thickness. For the transition area of 20 mm as well as the length of 50 mm, the regulation regarding the width dimension of 400 mm according to point 12.2.4.3.5 does not apply.

12.2.8.4. Foot Rests and Hand Holds

Athletes must have means to hold on to the sled in case of a crash. Any sled must therefore have a sufficient number of handholds.

12.2.8.5. Steering ropes and Steering handles

Steering ropes that connect the steering handles to the steering mechanism must be of sufficient strength to withstand the forces encountered in practice and competition. Steering handles must be constructed in such a way that they will withstand the stresses encountered during practice and competition. Steering handles may be kept in place by the use of rubber or rubber-like material.

12.2.8.6. Carrying Bars

Bobsleighs may be fitted with carrying bars in the front bumper to facilitate transportation. In that case, carrying bars must be fitted in such a way that they remain retracted from start to finish and that under no circumstances they

become detached during a heat. Rubber or rubber-like material may be used to keep the carrying bars in place.

12.2.8.7. Padding materials

Padding on the inside of the bobsleigh, used to protect athletes from injuries and that is in accordance with the rules of 12.2.3 and 12.2.4 may contain rubber or rubber-like material.

For each athlete padding of 2 x 200 x 200 mm or alternatively 4 x 150 x 150 mm plus an additional piece of “DIN A4” format for the driver’s seat (contact to the bottom of the sled) are permitted. Furthermore padding may be used to cover parts of the frame to a maximum surface area of 10 dm² and a maximum thickness of 50 mm. Furthermore, it is possible to attach a padding of 200 x 200 mm to all junctions between the frame and the cowling on the sled. These dimensions are not cumulative.

A hole or slit/recess in the padding must be allowed to measure the 650 mm from the bottom of the sled.

It is not permitted to attach any additional materials to the cowling cutout (Fig.4). Padding located 8 cm below the cowling cutout parallel to the top is permitted. All other dimensions must be respected.

The inside edges of the cowling can be covered with two strips of padding which must be placed in a symmetrical manner one on each side. This padding must be within an area 50mm back from the center of the cowling cut out and must not be further back than 500mm. The padding must be placed on the inside edge of the cowling according to Figure 2b. The dimensions of the padding can be a maximum 150mm length x 30mm width x 10mm thickness.

12.3. Miscellaneous

12.3.1. Purpose of 12.3

12.3.2. Principles and Properties

12.3.2.1. Applicability

12.3.2.2. Tolerances and Limits

12.3.2.2.1. Use of measuring equipment

- a) Equipment used to establish whether bobsleigh equipment complies with the Rules must be used in a professional manner and according to the manufacturer’s instructions.
- b) The systematic and non-systematic errors of the testing equipment used for testing bobsleigh materials must be known to the Material Controller.

- c) Systematic and non-systematic errors of the measuring equipment used must be considered when testing bobsleigh materials. Tolerances of testing equipment should be discounted to the advantage of the teams or athletes.
- d) In case of in situ-testing measurements indicating a violation of the rules that could result in disqualification, the measuring process must be repeated under controlled conditions.

12.3.2.2.2. Quality of testing equipment

- a) The testing equipment used for testing bobsleigh materials should be fit for that purpose.
- b) All measuring instruments used in bobsleigh testing must be fitted with a label indicating the measuring tolerance.
- c) Passameters with equivalent tolerances may be used.
- d) Radiuses and convexity must be tested by using IBSF patterns.
- e) (Surface) Hardness must be measured by using calibrated measuring equipment
- f) The composition of bobsleigh materials must be established by using calibrated measuring equipment.
- g) Calibration of testing equipment must be performed on a regular basis and according to manufacturer's recommendations. In case of calipers, micrometers and Passameters, calibration standards must be available during testing.
- h) Equipment used to perform in-situ measurements must be calibrated for that purpose.

12.3.3. List of Drawings and Figures

- a) Figure 1 is a side view and
- b) Figure 2 is a top view of a bob resting on a horizontal surface.
- c) Figures 3 A, B, C and D define the planes with which the 'concave shape' rules will be controlled.
- d) Figure 4 clarifies the flange required at the front of the pilot's cut-out.
- e) Figure 5 shows the controlled dimensions of the front bumper cross-section.
- f) Figure 6 defines the shape of the front and rear bumpers from a top view and at the point of contact to the wall.
- g) Figure 7 clarifies dimensions and tolerances of the side push bar stanchion.
- h) Figures 8, 9 and 9a depict the essential constructive elements top view and (partly sectional) side view, respectively, with dimensions corresponding to a 2-man bob.
- i) Figure 10 is a (partly sectional) front view of the frame and front axle region of a 2-man bob.
- j) Figure 11 depicts the top and side views of the runner carriers of a 2-man bob.

-
- k) Figure 12 depicts the front view and bottom view of the front axle of a 2-man bob.
 - l) Figure 13 depicts the rear axle of a 2-man bob.
 - m) Figures 14 and 15 depict the essential constructive elements top view and (partly sectional) side view, respectively, with dimensions corresponding to a 4-man bob.
 - n) Figure 16 is a (partly sectional) front view of the frame and front axle region of a 4-man bob.
 - o) Figure 17 depicts the top and side views of the runner carriers of a 4-man bob.
 - p) Figure 18 depicts the front and bottom view of the front axle of a 4-man bob.
 - q) Figure 19 depicts the rear axle of a 4-man bob.
 - r) Figure 20 depicts the construction of the brake (2-man/2-woman and 4-man bob).
 - s) Figure 21 shows the essential dimensions of the runners (2-man/2-woman and 4-man bob).
 - t) Figure 23 depicts the connection between the cowling and the frame, the position relative to the division line of the forward travel stops limiting the movement of the cowling relative to the frame and the position relative to the rear axle of the rear travel stops limiting the movement of the cowling relative to the frame.

12.4. Drawings

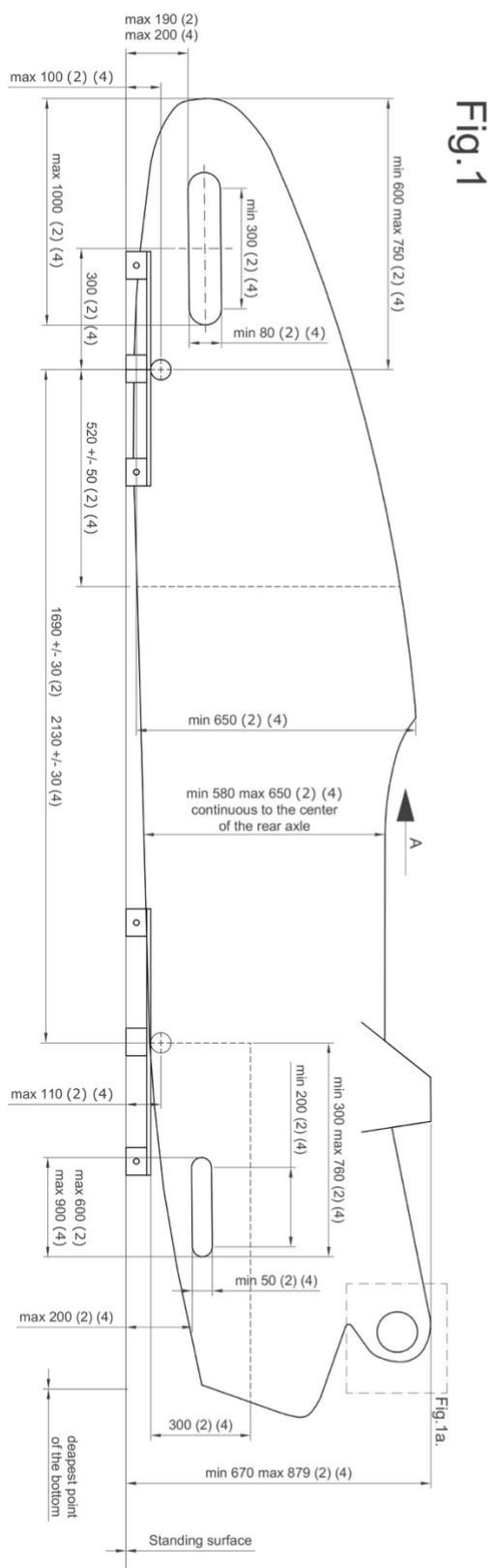

Fig. 1a.

alle Maße in mm | all dimens. in mm | todas dimens. en mm
no scale

Fig. 2

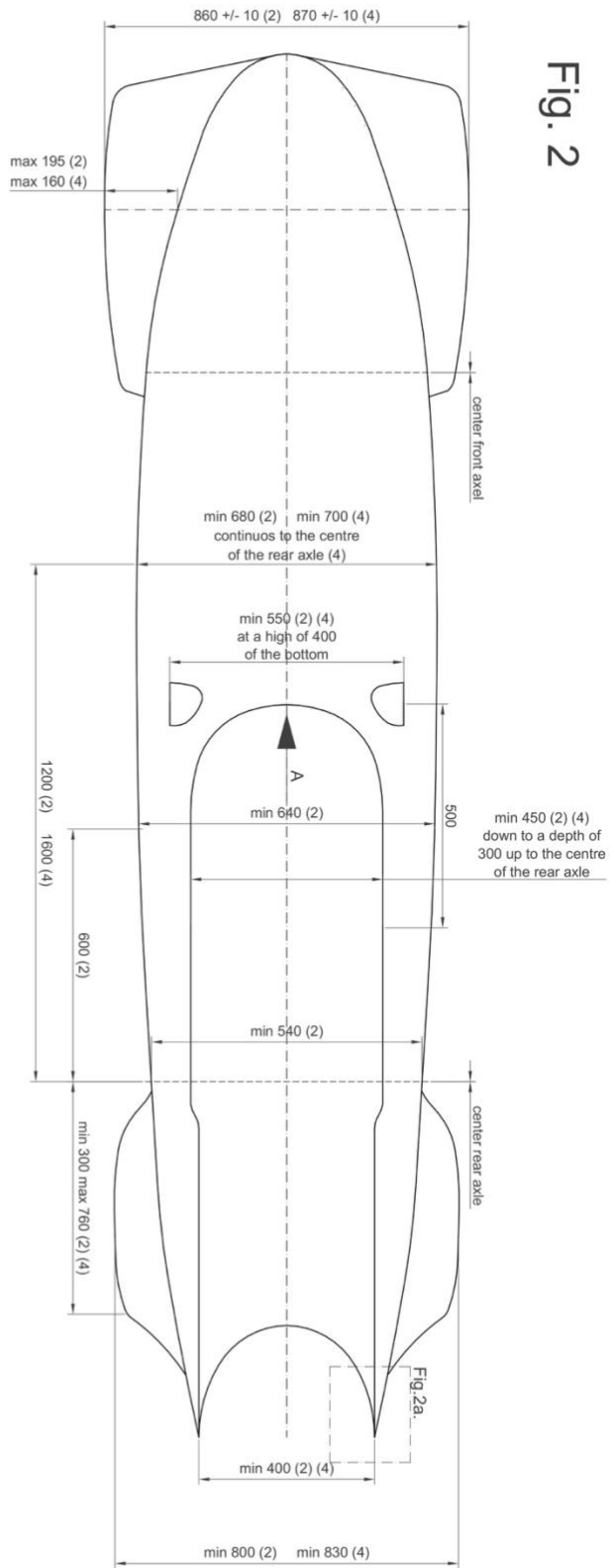

Fig. 2a.

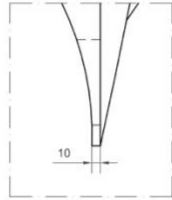
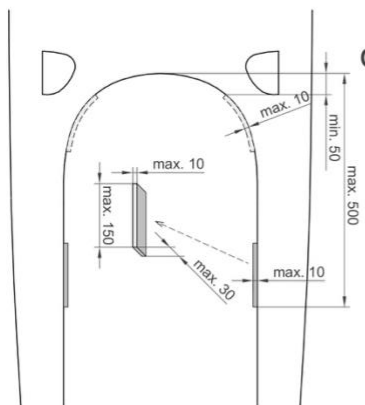
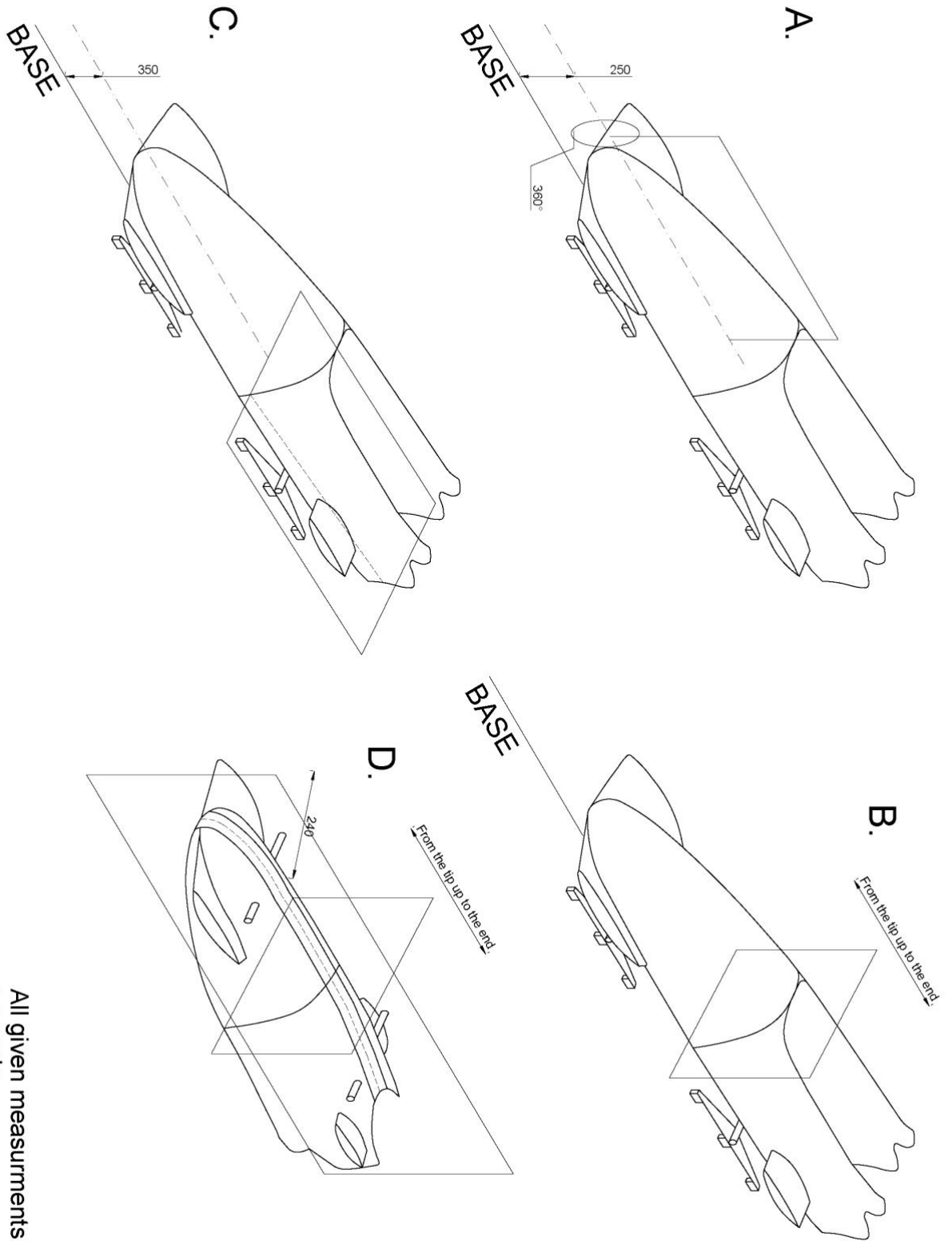

Fig. 2b.



alle Maße in mm | all dimens. in mm | toutes dimens. en mm
no scale

Fig.3



All given measurements in mm
no scale

Fig.4
View A of Fig. 1 and 2

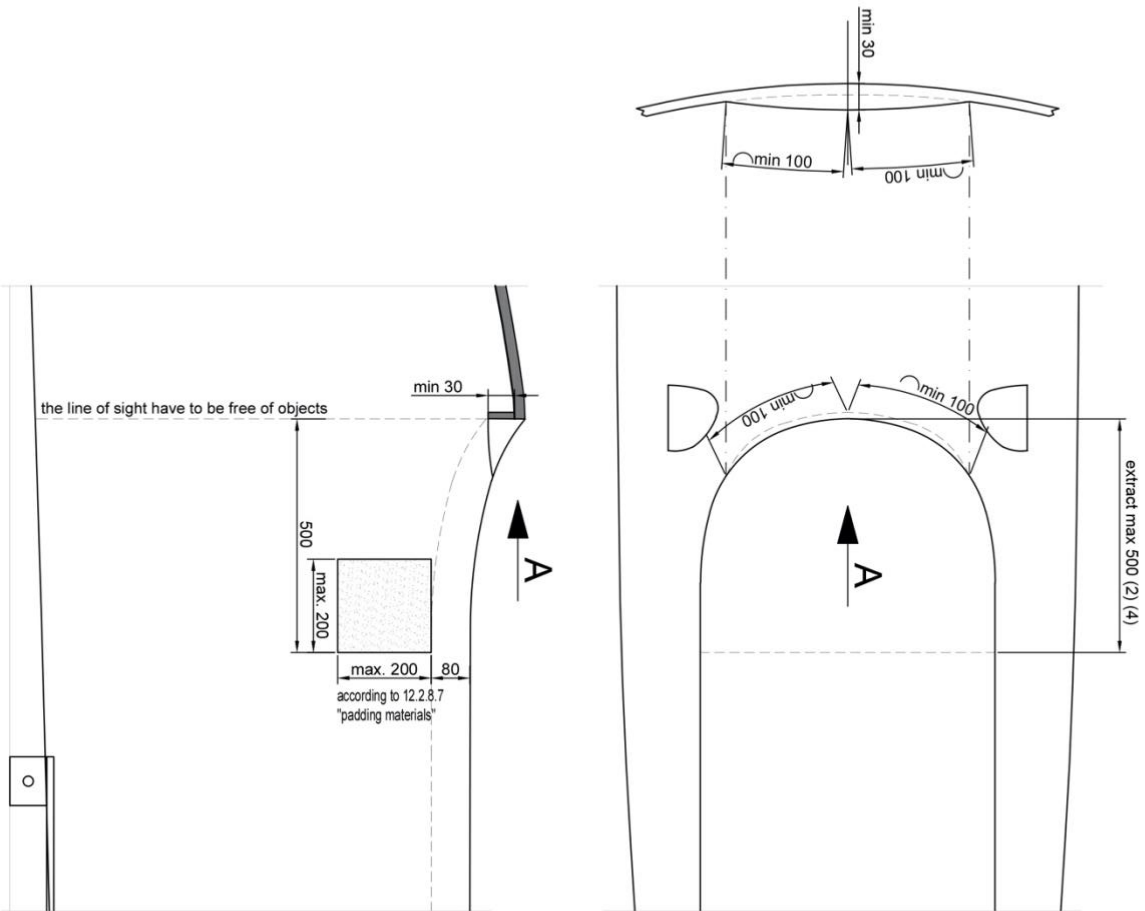

All given measurements in mm
no scale

Fig.5

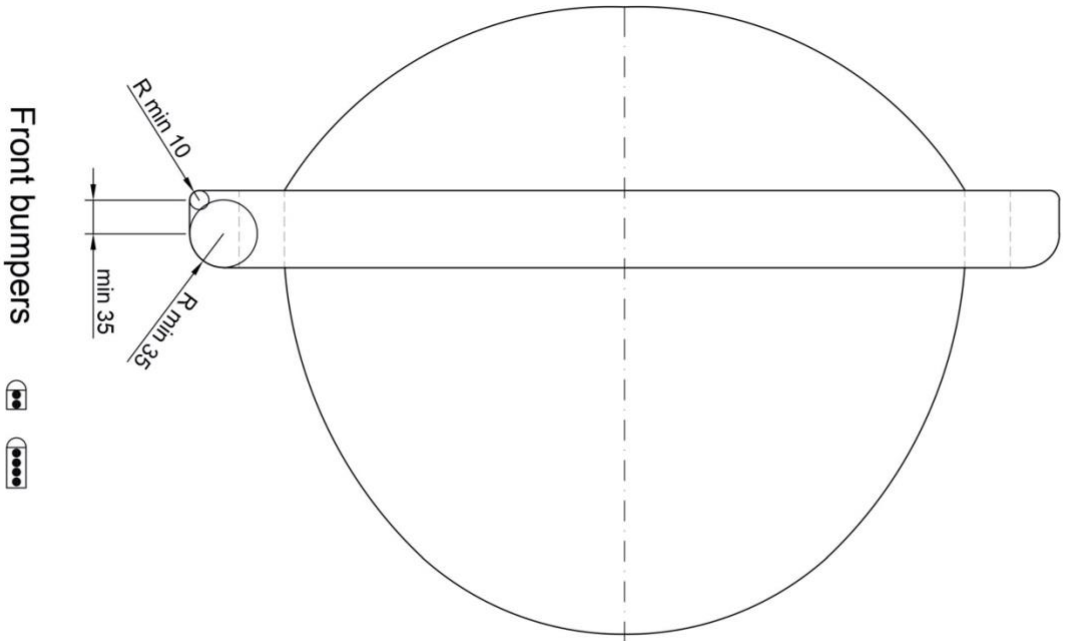

Front bumpers



Fig.6

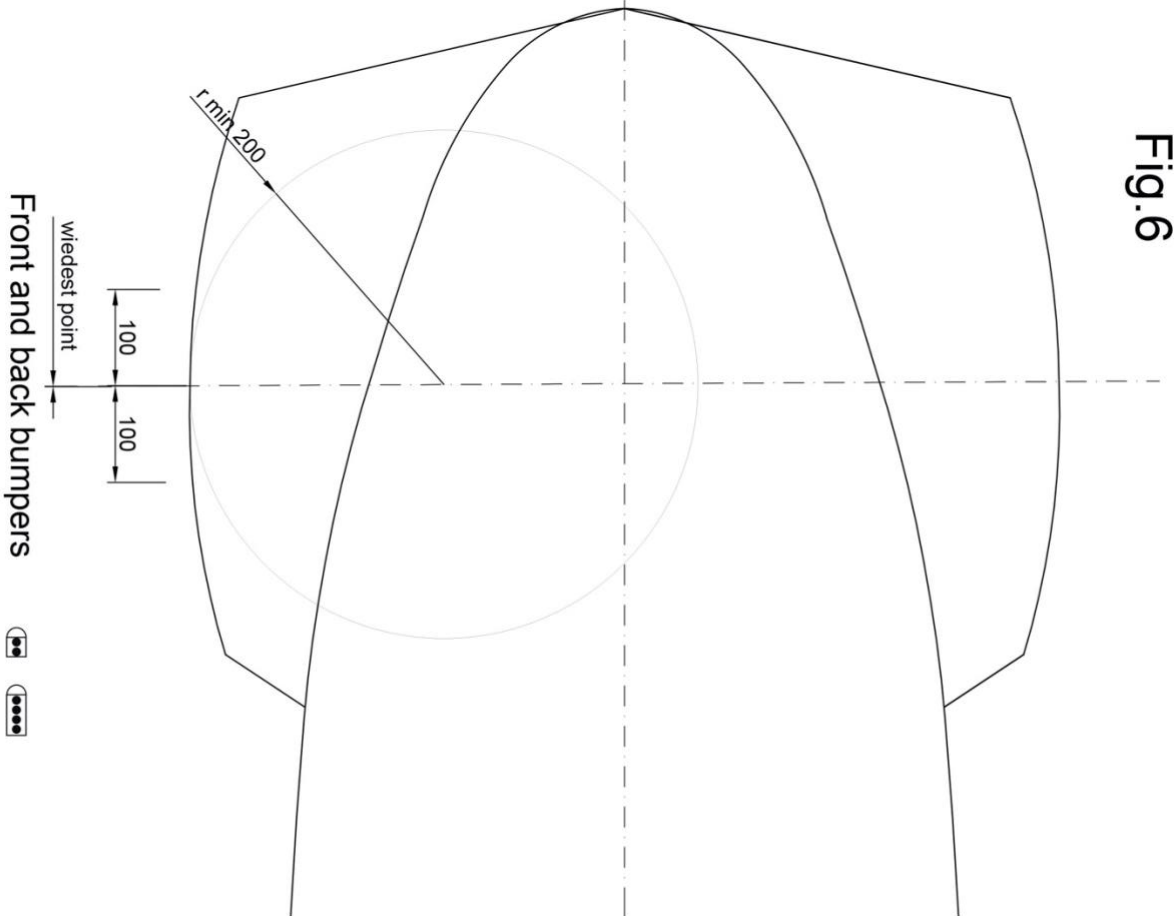

Front and back bumpers



All given measurements in mm
no scale

Fig. 7

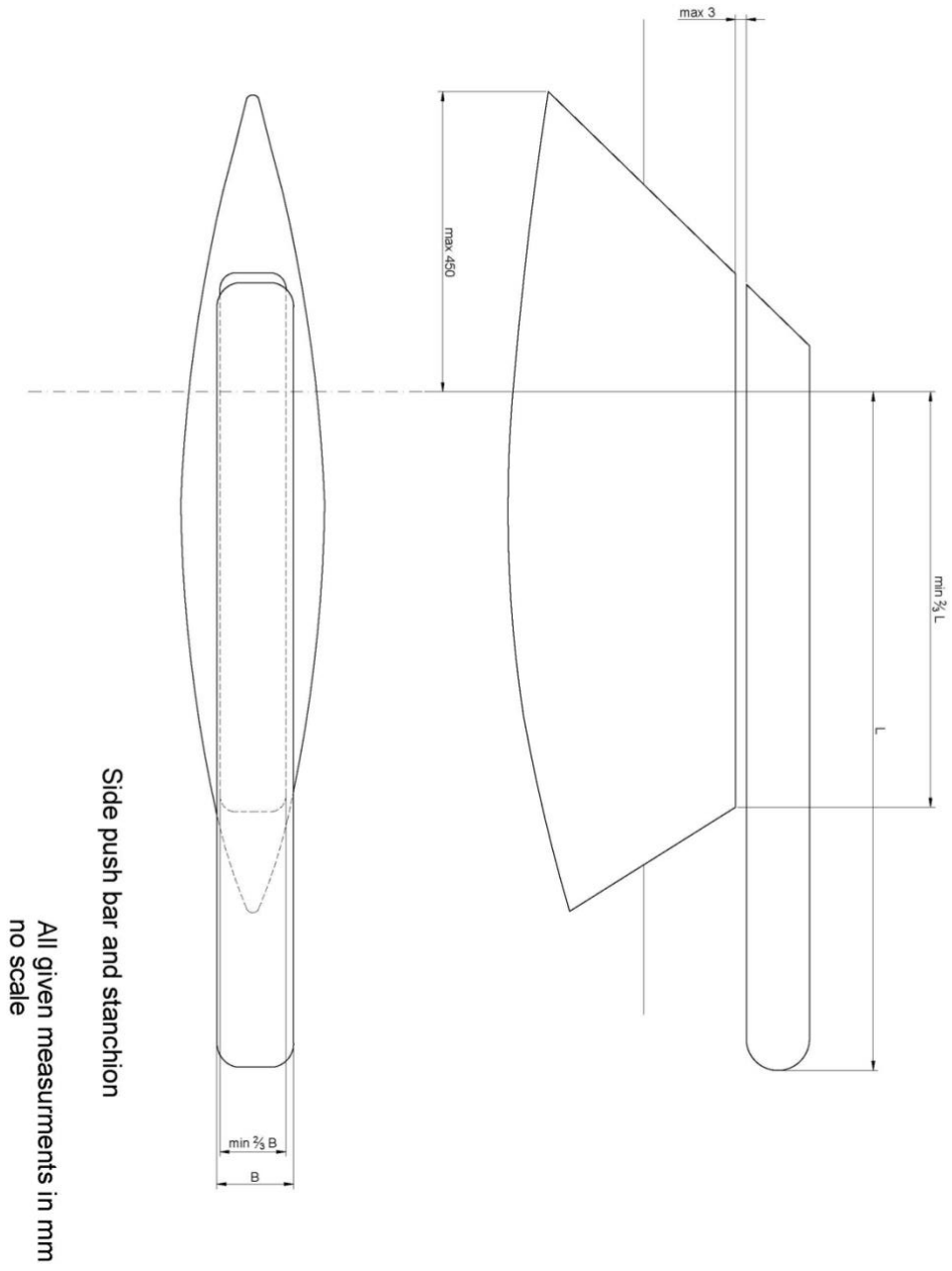
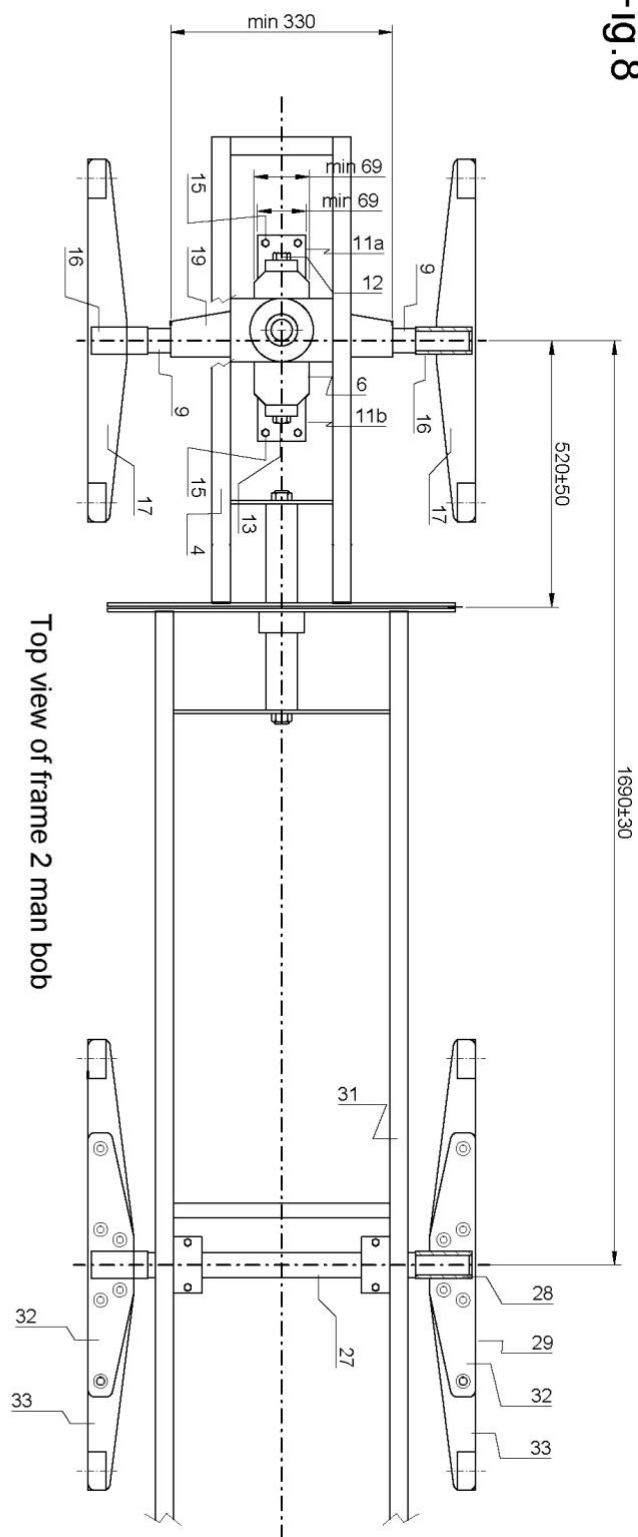
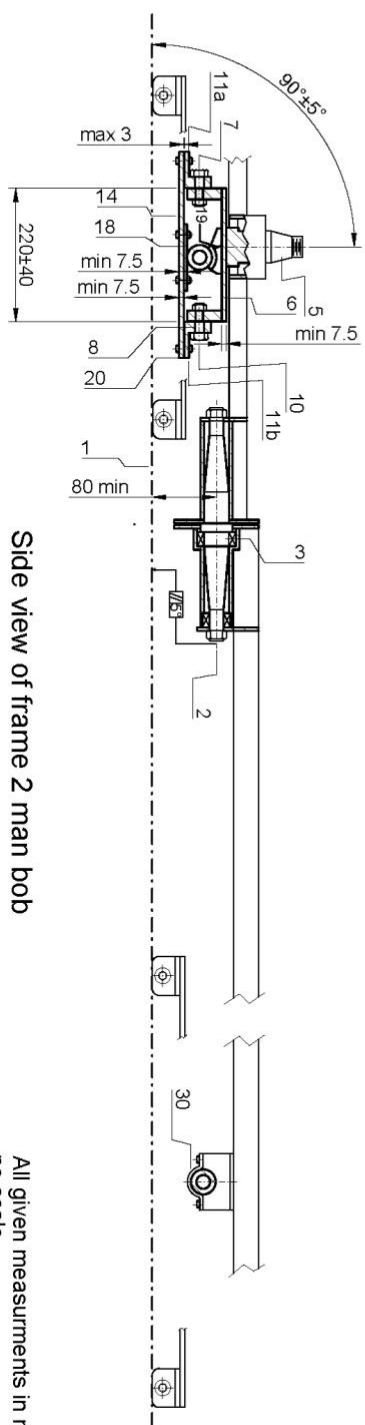

Fig.8



Top view of frame 2 man bob

Fig.9



Side view of frame 2 man bob

All given measurements in mm
no scale

Fig. 9a

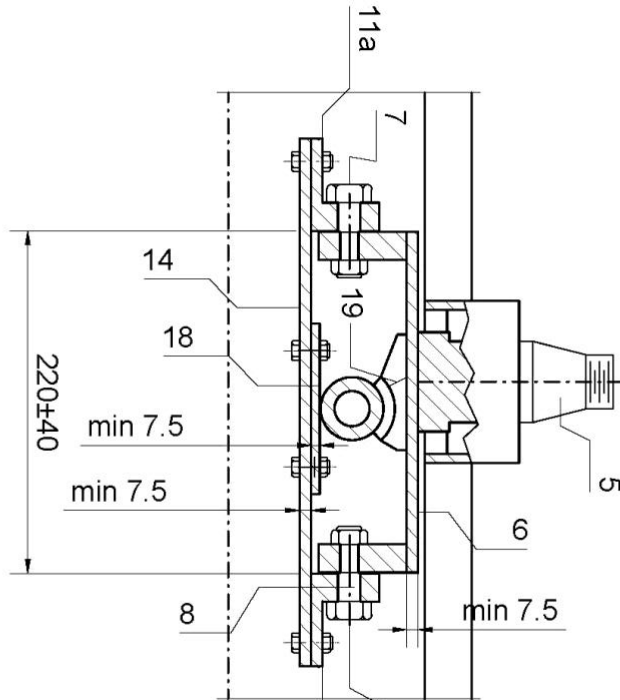
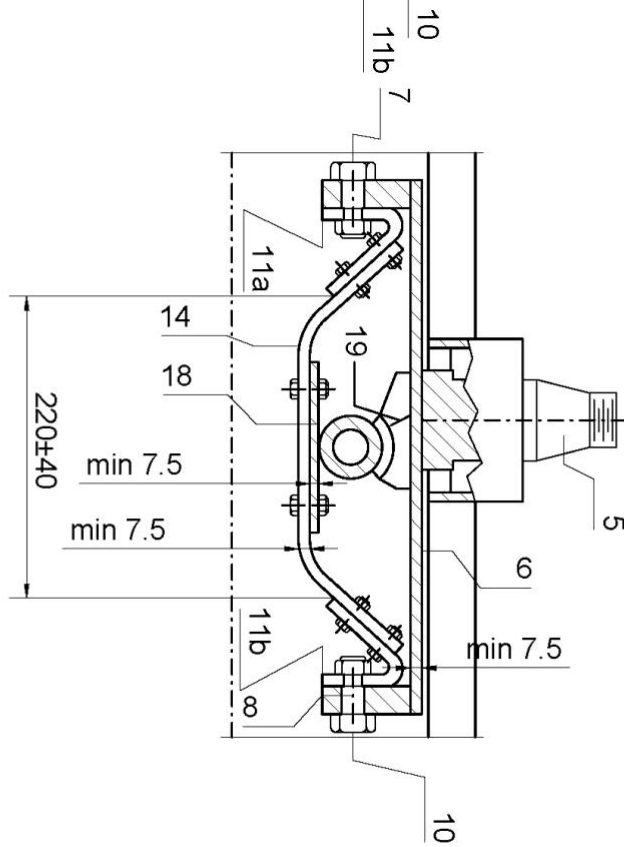

Fig. 9b



All given measurements in mm
no scale

Fig.10

Front view of frame 2 man bob

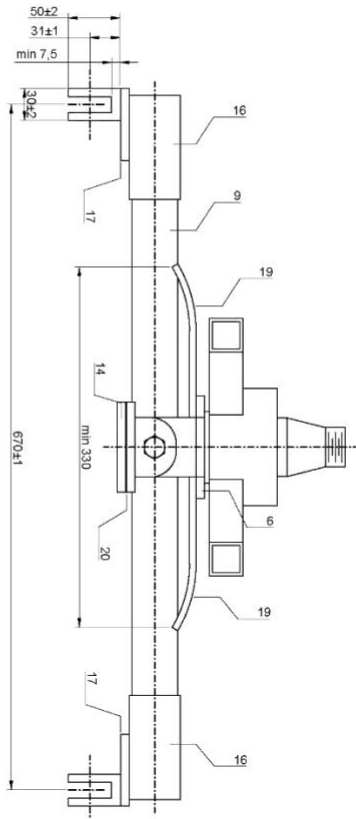
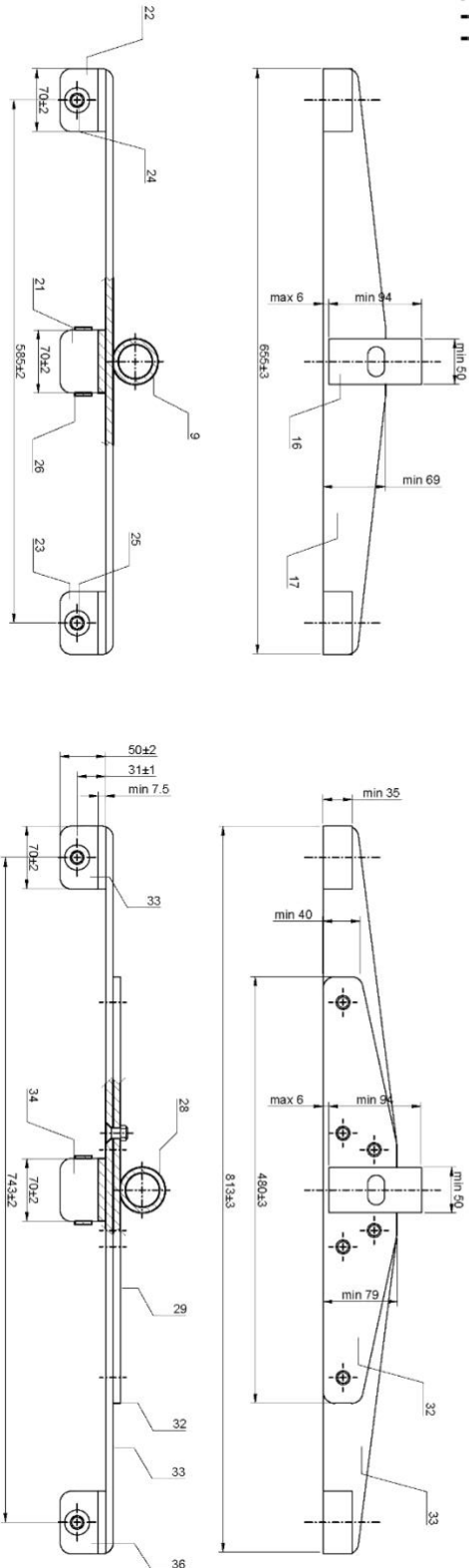

Fig.11

Runner carriers 2 man bob



All given measurements in mm
no scale

Fig. 12

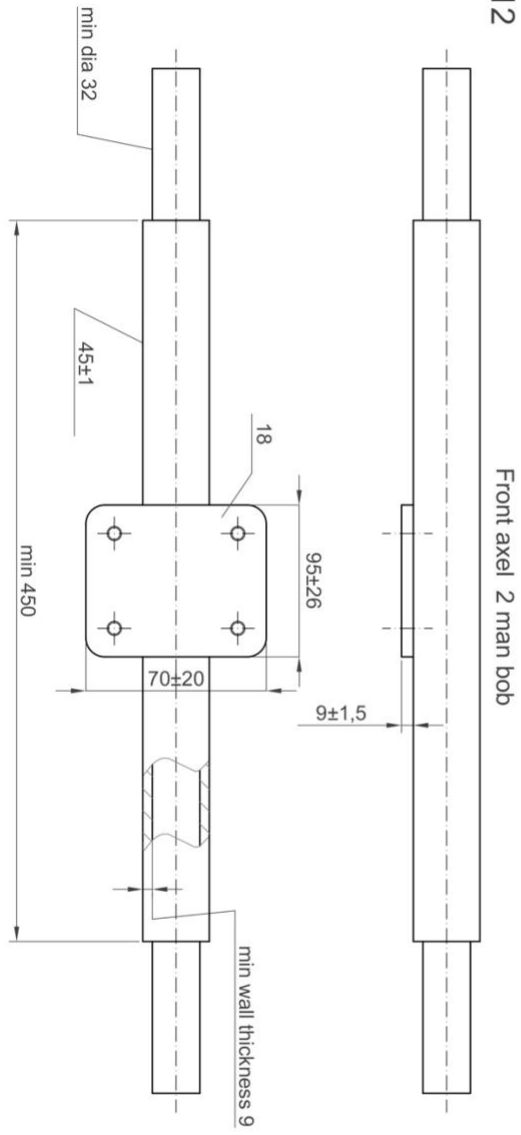
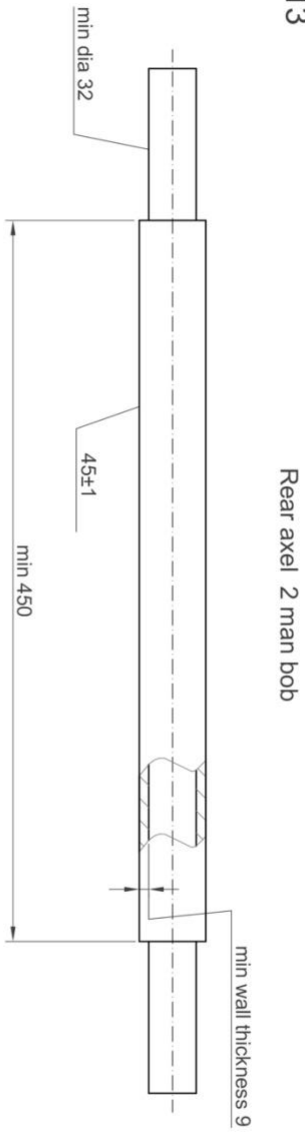
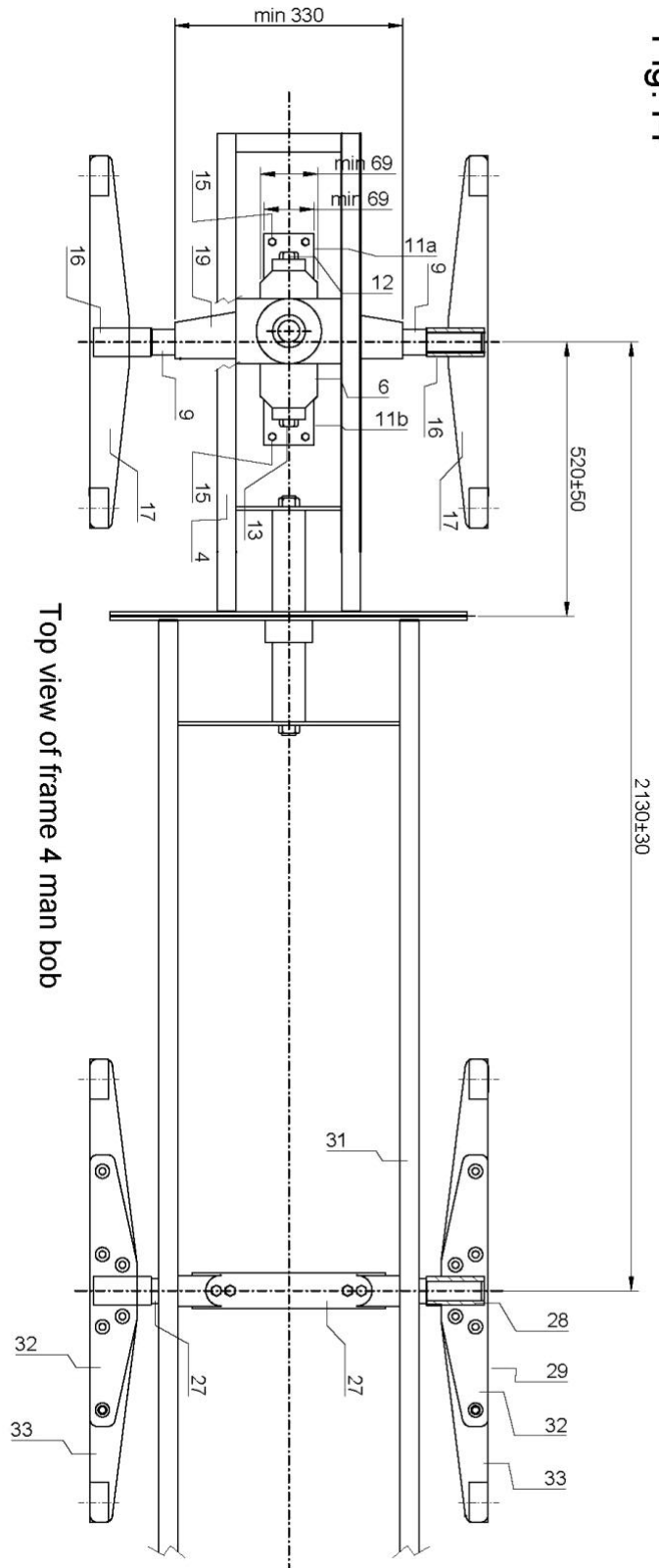

Fig. 13



alle Maße in mm | all dimens. in mm | toutes dimens. en mm

Fig. 14



Top view of frame 4 man bob

Fig. 15

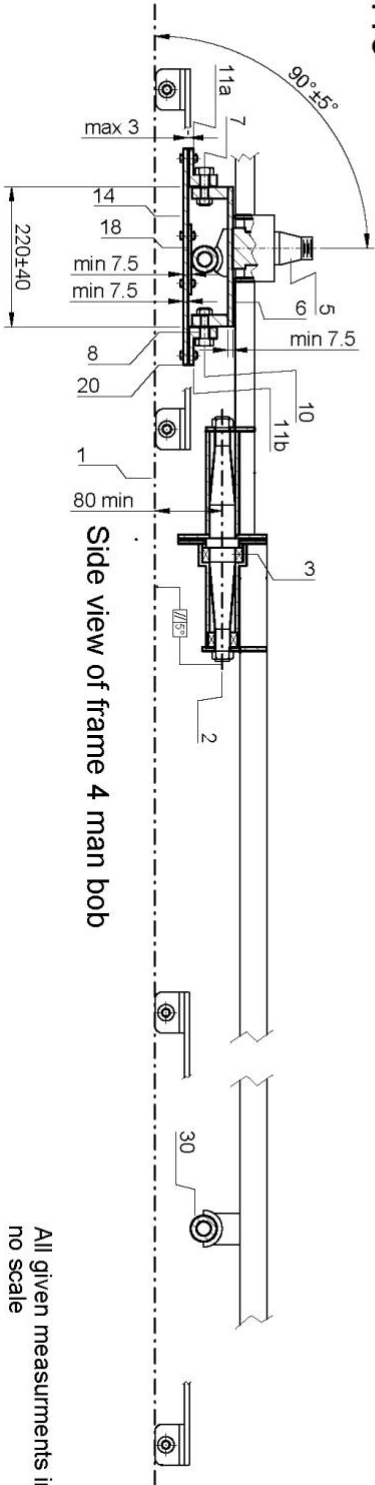

Side view of frame 4 man bob

All given measurements in mm
no scale

Fig. 15a

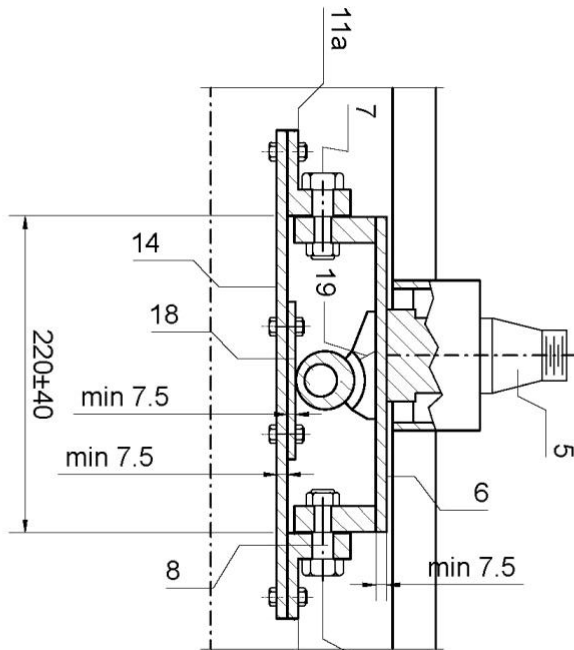
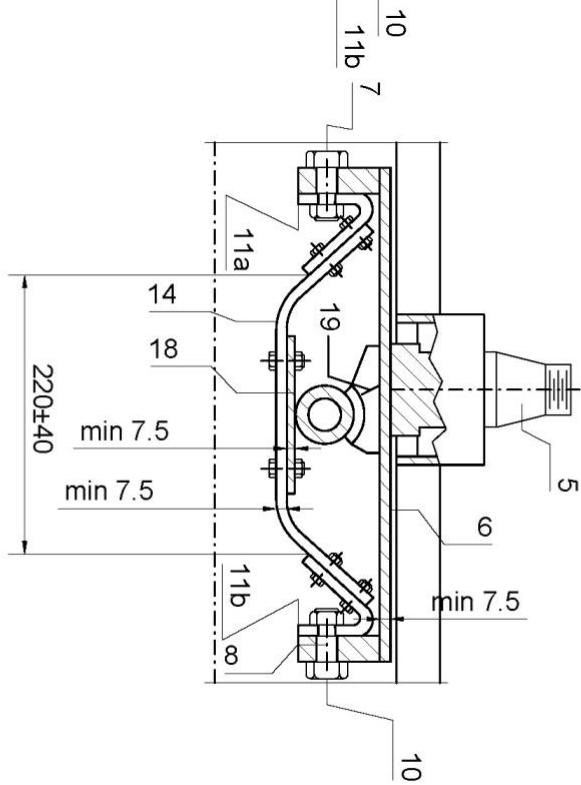

Fig. 15b



All given measurements in mm
no scale

Fig. 16 Front view of frame 4 man bob

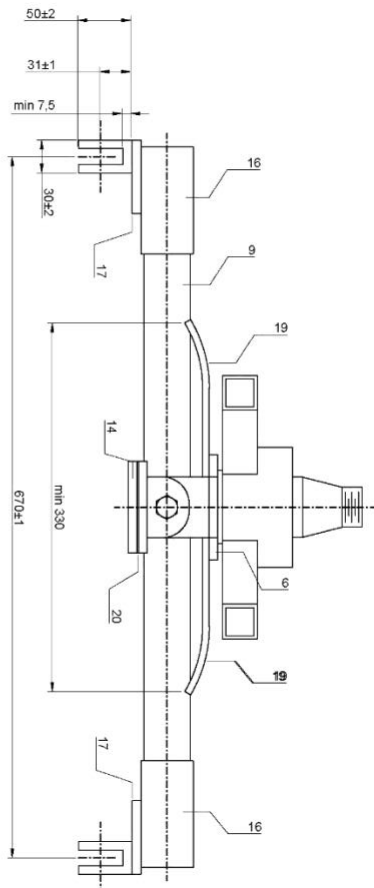
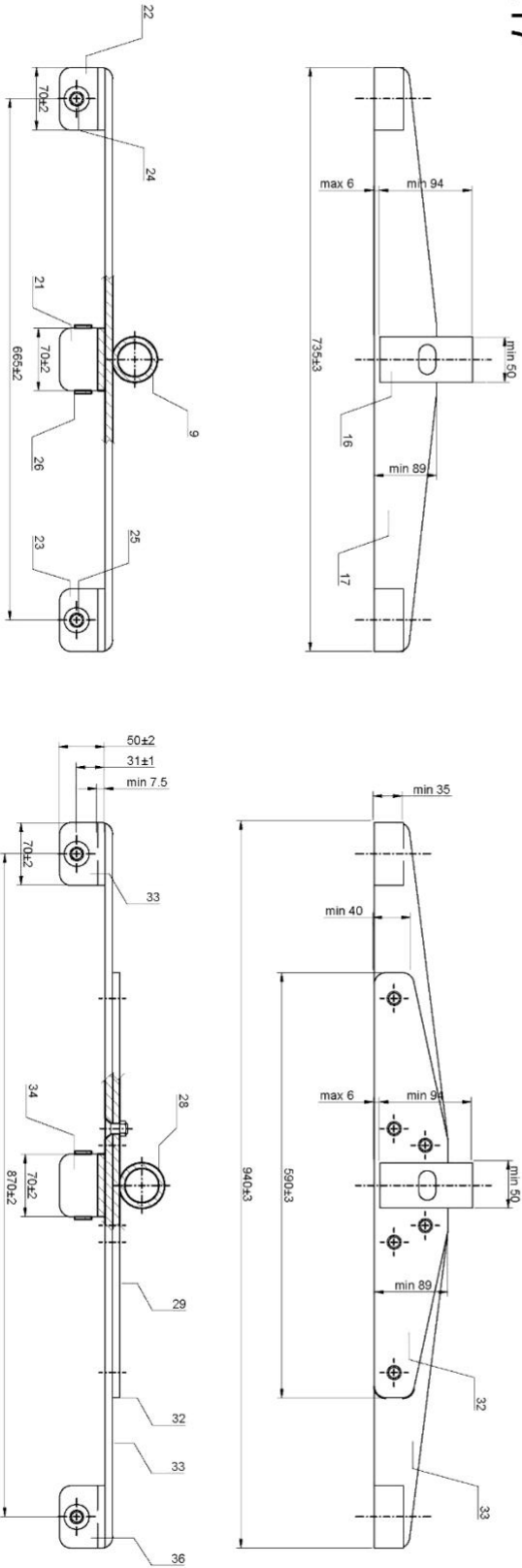

Fig. 17

Runner carriers 4 man bob



All given measurements in mm
no scale

Fig. 18

Front axel 4 man bob

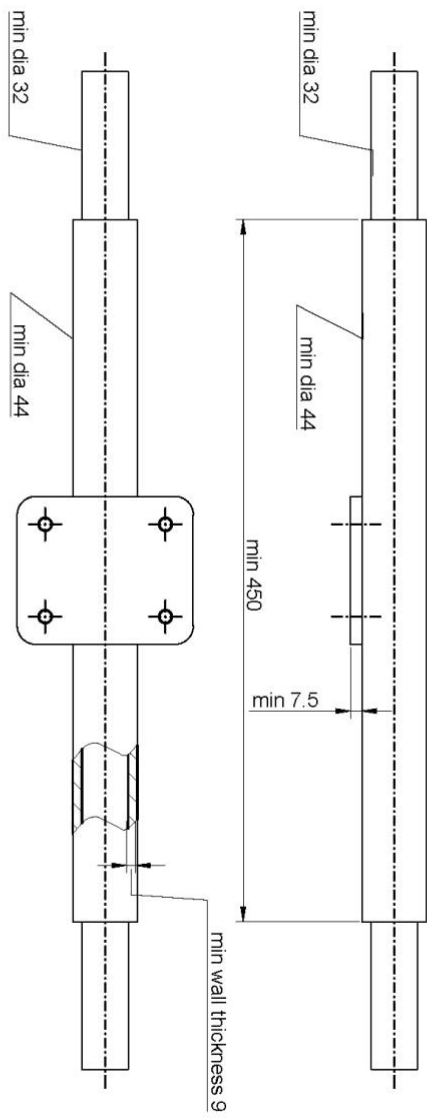
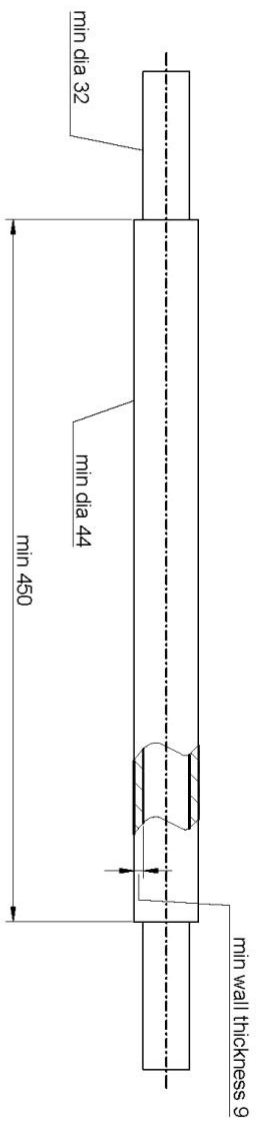

Fig. 19

Rear axel 4 man bob



All given measurements in mm
no scale

Fig. 20

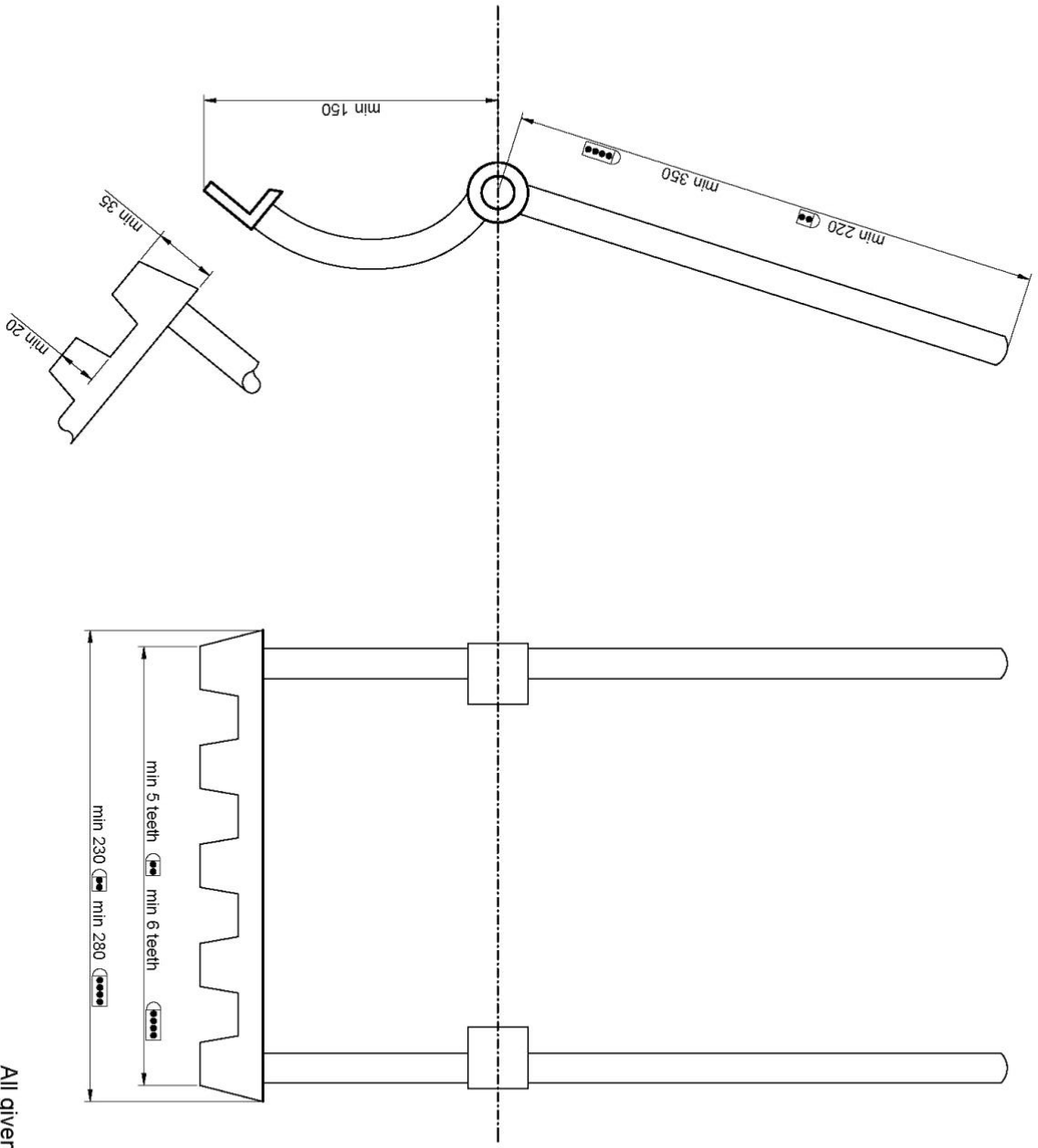

All given measurements in mm
no scale

Fig. 23

alle Maße in mm | all dimens. in mm | toutes dimens. en mm
no scale

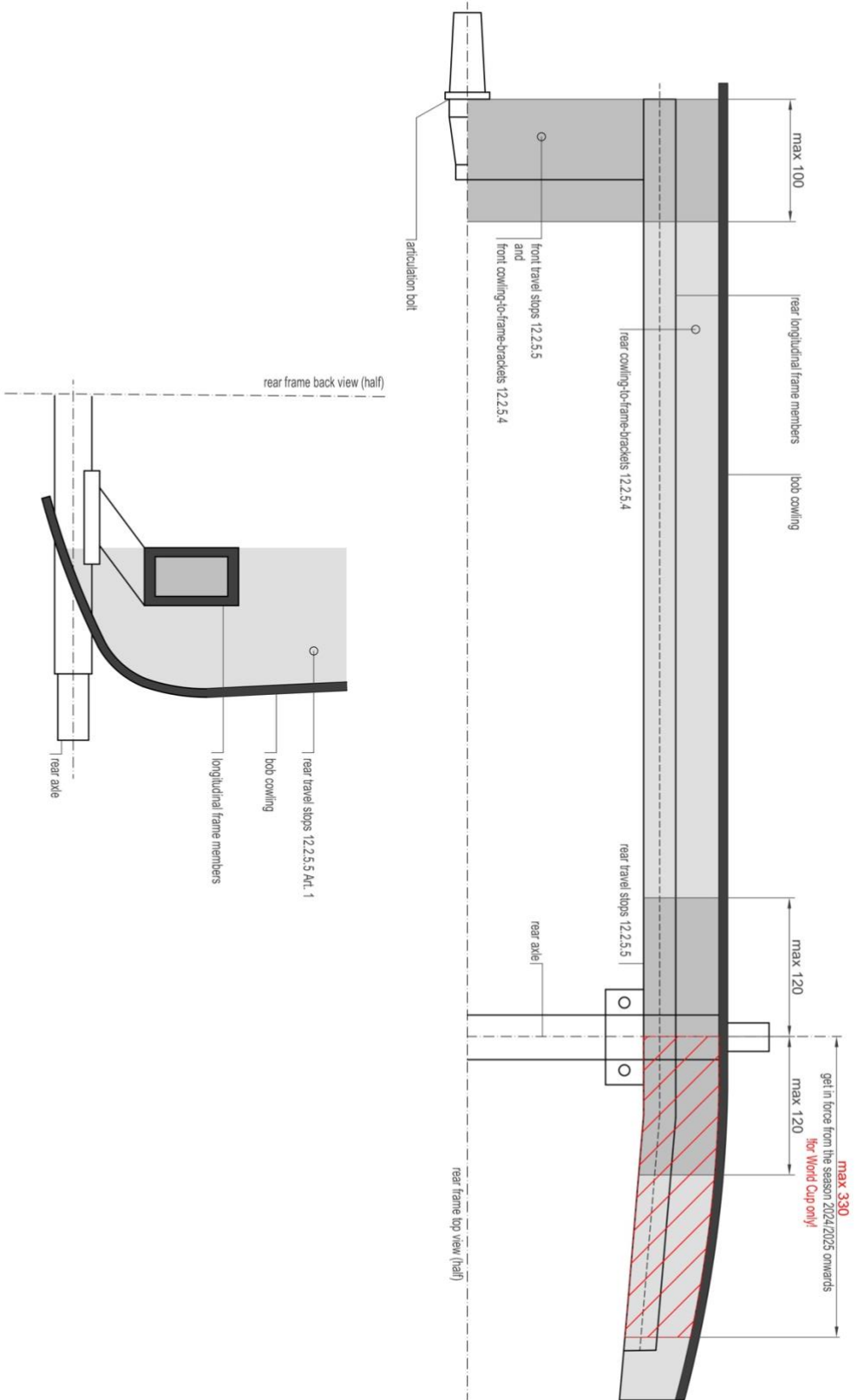

Fig. 24

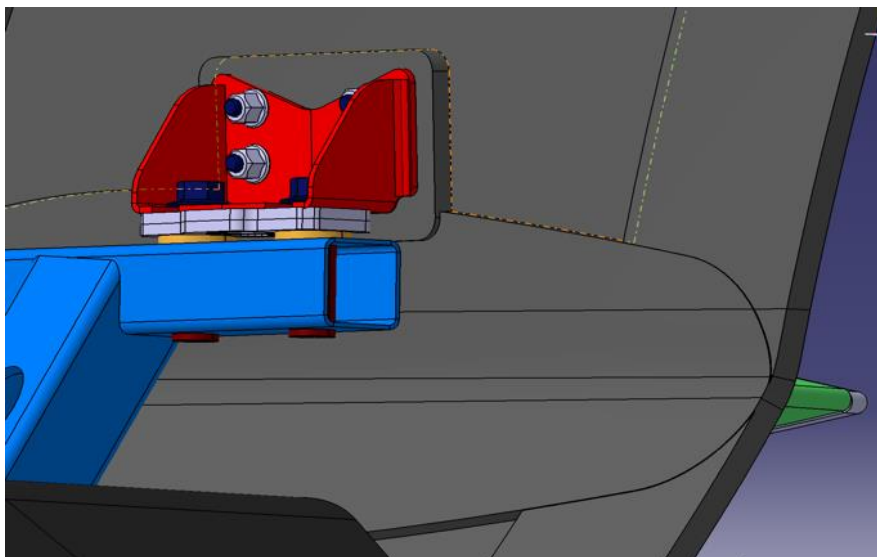

Fig. 25

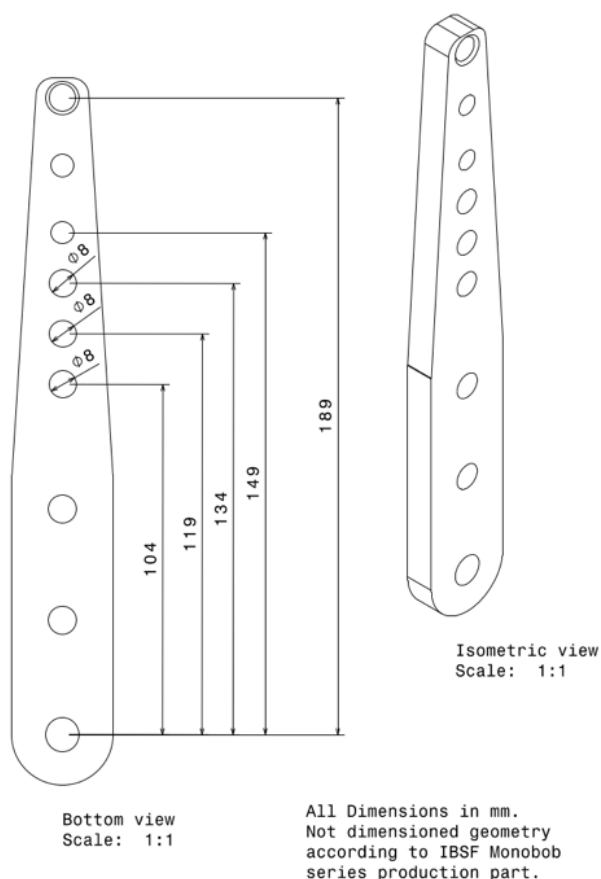
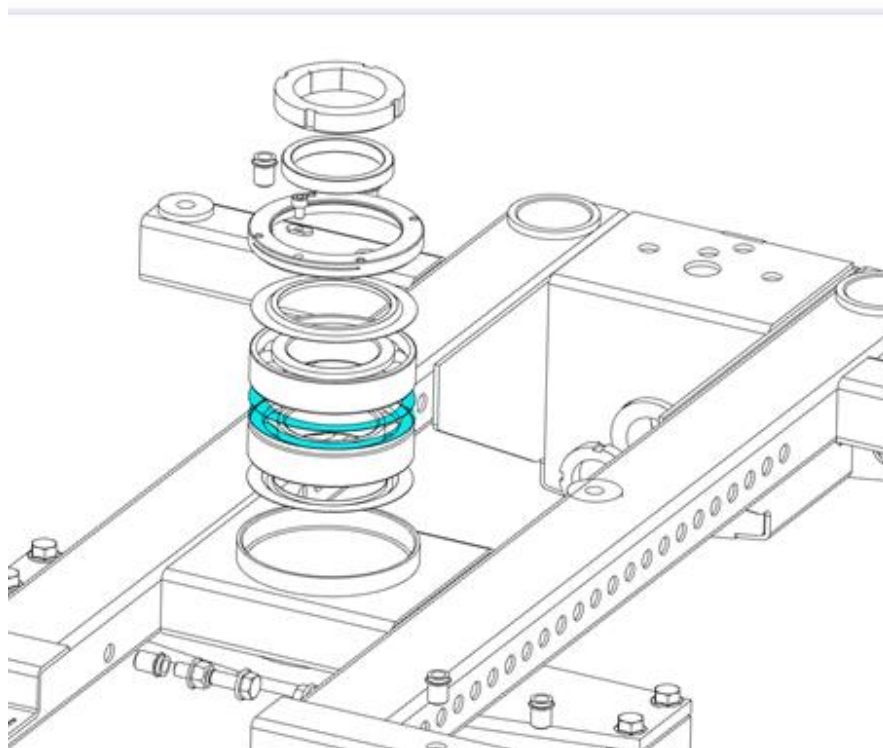

Fig. 26



13. MATERIAL SEIZURE

13.1. Procedure for the seizure of sled components for conformity tests

Empowered by the Jury and in the presence of at least one of its members, the IBSF Material Controller responsible directs the official representative of the Federation to which the sled belongs to remove or disassemble the component(s) to be tested.

13.2. The Form

Upon collecting the component(s), the IBSF Material Controller will fill in a form drawn up in six copies, stating:

- a) General data of the team / athlete whose sled is being tested
- b) The name of the competition and the venue
- c) The date and time
- d) A description of the component(s) taken
- e) The type of test(s) the laboratory is required to perform
- f) A blank space for entering the laboratory analysis results

The following people will sign the form:

- a) The Jury President
- b) The representative of the IBSF Material Controller
- c) The team captain or official representative of the Federation to whom the sled belongs

The five copies of the form will be sent to the following:

- a) One copy to the Jury President
- b) One copy to the IBSF President (via the Secretary General)
- c) One copy to the team captain or official representative of the Federation to whom the sled belongs
- d) Two copies to the laboratory, together with the container holding the component(s) to be tested

By returning one of the two copies of the form to the IBSF Secretary General, the laboratory confirms that it has received the container undamaged.

13.3. The Container

The seized components will be sealed in a container.

13.4. Remarks

The IBSF bears the costs of the laboratory analysis. In case of positive analysis results, the IBSF can order the costs to be reimbursed by the Federation to whom the sled belongs.

PROTOCOL FOR SEIZURE OF SLED COMPONENTS FOR CONFORMITY TESTS

Place: _____ Date: _____ Time: _____ Competition: _____

Event: _____ Nation: _____

Description of component/s taken: _____

Test/s required: _____

Name of Laboratory: _____

Laboratory result: _____

President of Jury Material Controller National Federation

Name: _____ Name: _____ Name: _____

Signatures: _____

The Laboratory _____ in the person of Mr. _____

acknowledges receipt of the official container bearing unbroken seals, from Mr.

on (date) _____ at (time) _____

Stamp: _____
(signature)

14. ADVERTISING GUIDELINES AND DRAWINGS

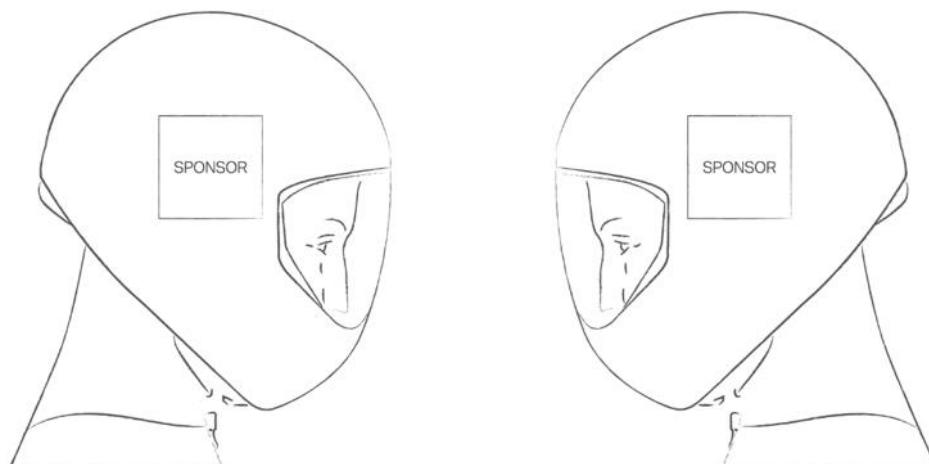

IBSF Right: Helmet (Bobsleigh & Skeleton)

Left and right side of the helmet, as close as possible to the visor Size: 50 cm 2

IBSF Marketing Properties

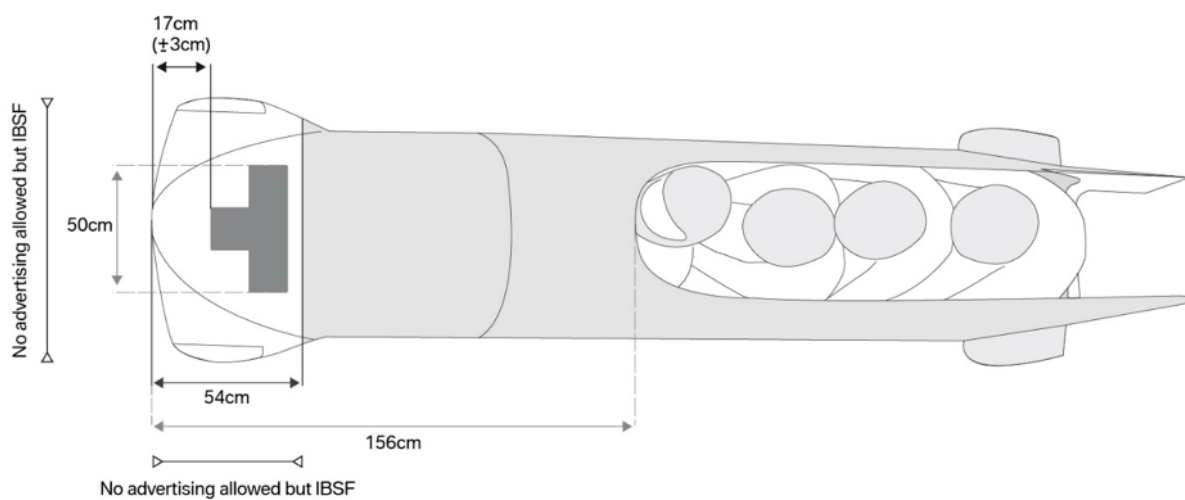

15. FINAL CLAUSE

15.1. Coming into Force

This edition comes into force on October 1st, 2024.

15.2. Modifications

The IBSF Executive Committee determines modifications to the IBSF International Rules.

15.3. Interpretation

If an article in these Rules should be ambiguously defined so that multiple interpretations are possible, the interpretation should be used that matches the underlying meaning for which the article was written.

APPENDIX 1

Complete list of repair, modification and/or maintenance work using the original spare parts.

- The original bolts of the connection between the frame and the cowling (designation: M12x40mm), see Fig. 24, placed vertically, may be replaced by bolts with a thread diameter of M12 having a minimum length of 40mm, in order to grant a continuous screw connection. Teams are allowed to drill through the connection between the frame and the cowling.
- Teams are allowed to sharpen the brake tines.
- Three additional holes, each 15 mm apart, may be drilled and threaded in the steering lever. See Fig. 25.
- The suspension of the steering cables may be individually adapted. Besides the original steering handles, custom-made steering handles may also be used.
- Any work that changes the aerodynamics is prohibited.
- Damages to the cowling, e.g. after a crash, may be repaired by the teams.
- Only the original seat shell provided by iXent is allowed as seat shell. Individual cushions and a seat support may be added. These may only be attached with a tape.
- Rubber or rubber-like material may be used instead of metal inserts at the cowling connections - 4 at the front frame and 4 at the rear frame.
- Original steering ropes may be replaced by own steering ropes.
- For the purpose of returning the runners in a neutral position, rubber or rubber-like materials may be used in the steering mechanism. Also the original rubber may be replaced by own rubber.
- Additional seat support is permitted, but must not be connected to the frame by a screw fixing. The seat support may only be fixed to the frame, seat shell and cowling with tape.
- A metal spacer ring of max. 2mm thickness may be installed between the two steering head bearings. See Fig. 26

16. GLOSSARY

Term / Abbreviation	Definition
DSQ – Disqualified	A ruling by officials that an athlete or team has broken or failed to observe the rules of the sport and cannot be considered for placing in the competition.
Unsportsmanlike behaviour	Unsportsmanlike behaviour includes in particular improper behaviour, bad or offensive language, not showing fairness or respect to other people and/or causing intentional damage.
DQB - Disqualification for unsportsmanlike behaviour	A disqualification due to any violation of the Olympic Charter, of the World Anti-Doping Code, or any other serious breach of applicable regulations issued by the IBSF and the IOC.
DNS – Did Not Start	If an athlete or team has been drawn for the competition but did not start.
DNF – Did Not Finish	If an athlete or team does not cross the finish timing eye.
Member = National Federation = Nation	These three terms are used synonymously describing the National Federations that are Members of the IBSF representing their country internationally in bobsleigh and/or skeleton sport (IBSF events). They have to comply with IBSF Rules and Regulations.
Congress	The Congress is the highest authority of the IBSF, and it consists of the Delegates nominated by the Members and the Executive Committee.
Quota	A restriction that limits the number of participants in any IBSF competition and Olympic Winter Games.
Ranking List	A listing of athletes/teams according to IBSF system of rating for each series.
to be ranked	All athletes that finish the race without being classified as DNS, DNF, DSQ or DQB are being ranked in a race.
International Jury License	A formal permission from IBSF to a person to take part in the official IBSF competitions as a Jury President or Jury Member. To obtain it the candidate has to pass the International Jury Exam.
Abrasive	Material (e.g. sandpaper) used to polish the runners.
Gauge	An instrument used to measure the runner radius.
Electronic Measuring Devices	Any instruments used to measure speed, temperature, G-force etc.
OWG	Olympic Winter Games
WC	World Cup
WCH	World Championships
AC	Asian Cup
EC	Europe Cup
ECH	European Championships
ICC	Intercontinental Cup
NAC	North American Cup
ITP	International Training Period